



Diode Characteristics

EXP.NO: 1

Name of experiment: Diode Characteristics

Purpose of experiment: To study and plot the V-I characteristics of a diode. (Relationship between V_{AK} and I_A).

Apparatus: 1. ST2712 board. 2. DC Voltmeter. 3. DC Ammeter. 4. Diode 1N4007 (on board) 5. Potentiometer 5K(1/4W) 6. Resistance 1K(1/4W).

Theory : A diode is the simplest sort of semiconductor device. Broadly speaking, a semiconductor is a material with a varying ability to conduct electrical current. Most semiconductors are made of a poor conductor that has had impurities (atoms of another material) added to it.

P – N junction characteristics

The PN junction is not an ideal rectifier diode having infinite resistance in the reverse direction and no resistance in the forward direction. Referring to Fig. 1.1 , in the forward direction (forward biased) it can be seen that very little current flows until a certain voltage has been reached. This represents the work that is required to enable the charge carriers to cross the depletion layer. This voltage varies from one type of semiconductor to another. For germanium it is around 0.2 or 0.3 volts and for silicon it is about 0.6-0.7 volts.

In fact it is possible to measure a voltage of about 0.6-0.7 volts across most small current diodes when they are forward biased. Power rectifier diodes normally have a larger voltage across them but this is partly due to the fact that there is some resistance in the silicon, and partly due to the fact that higher currents are flowing and they are operating further up the curve. From the diagram it can be seen that a small amount of current flows in the reverse direction (reverse biased). It has been



exaggerated to show it on the diagram, and in normal circumstances it is very much smaller than the forward current.

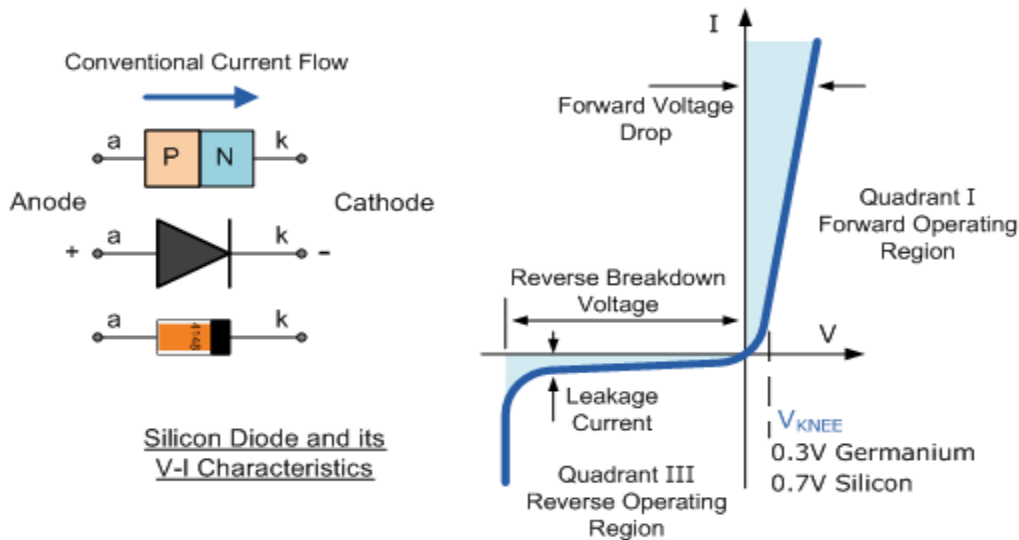

Figure.1.1. Silicon Diode V-I Characteristic Curve

Procedure:

1. Connect the circuit as shown in Fig. 1.2.
2. Switch ON the power supply on the board.
3. Vary the potentiometer P1 in fully counter clockwise direction and observe that both ammeter and voltmeter read zero.
4. By varying the potentiometer P1, increase the value of V_{in} carefully and in steps as in table (1) and read the anode current I_A for each step. Record your results in the table.
5. Switch OFF the power supply of the board.
6. Sketch your obtained results in graph paper
7. Connect the circuit as shown in Fig1.3.
8. Repeat steps 2 to 6. Record your results in table (2).

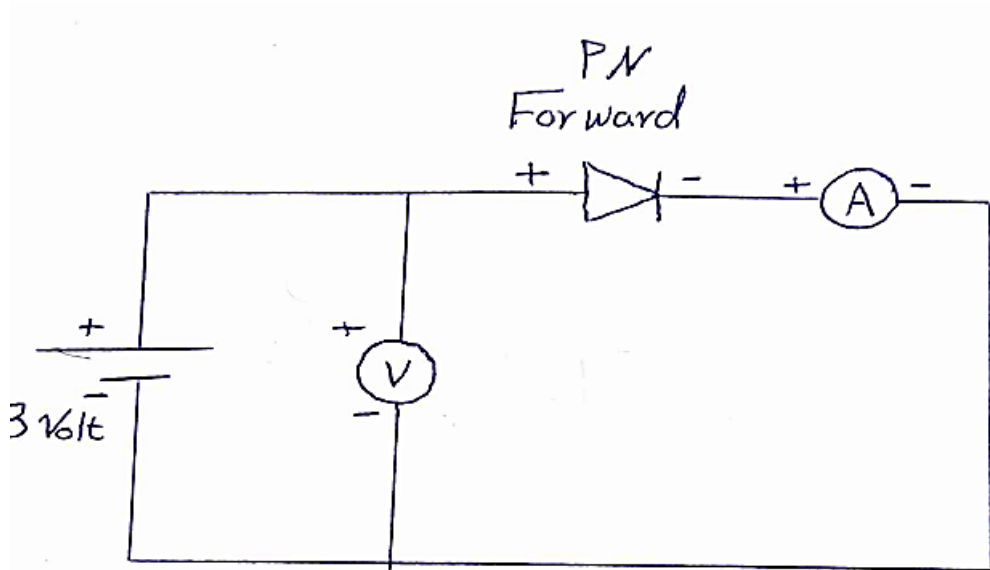

Figure1.2. the practical circuit for forward Diode characteristics.

Table (1) Results Obtained for forward characteristics of the Diode

| | | | | | | |
|--------------|---|-----|---|-----|---|---|
| $V_{in} (V)$ | 0 | 0.5 | 1 | 1.5 | 2 | 3 |
| $I_A (mA)$ | | | | | | |

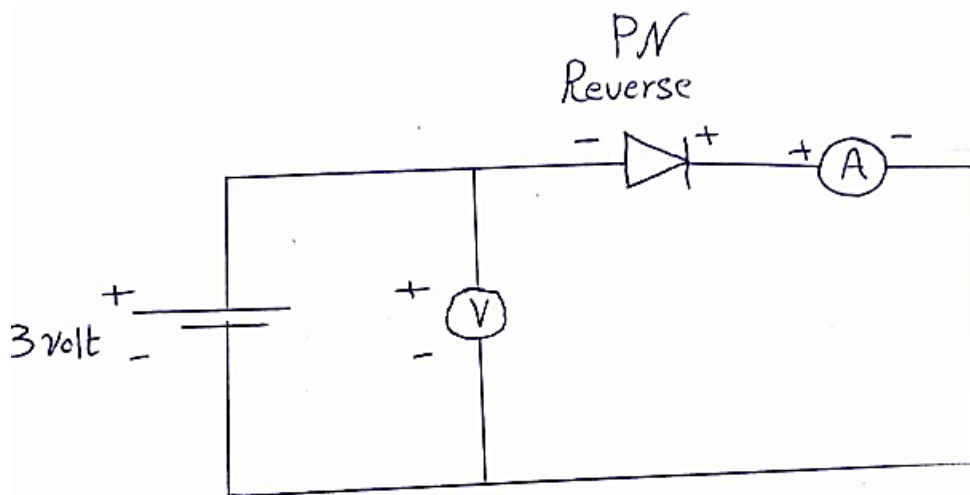

Figure1.3. the practical circuit for reverse Diode characteristics.

Table (2) Results Obtained for reverse characteristics of the Diode

| | | | | | | |
|---------------|---|------|----|------|----|----|
| $V_{in}(V)$ | 0 | -0.5 | -1 | -1.5 | -2 | -3 |
| $I_A (\mu A)$ | | | | | | |



Discussion

1. Comment about the obtained results ?
2. What is the benefit of (1 Ω , and 1k Ω) resistances?
3. If the maximum current of the diode c/c cct. is (22 mA) can you determine the r.m.s voltage of the source?
4. If you have number of diodes with maximum current of 70mA each, what do you do if the required load draws 240mA, let you have similar diodes in drop voltage?
5. If you have a type of diodes with (20 V) PIV, and you have AC power supply with (40 V) r.m.s voltage , What do you do ?
6. What the advantages and disadvantages of the parallel & series connected of the diodes ?
7. If you like to buy a diode from a market what are the important parameters that you must take in mind ?