

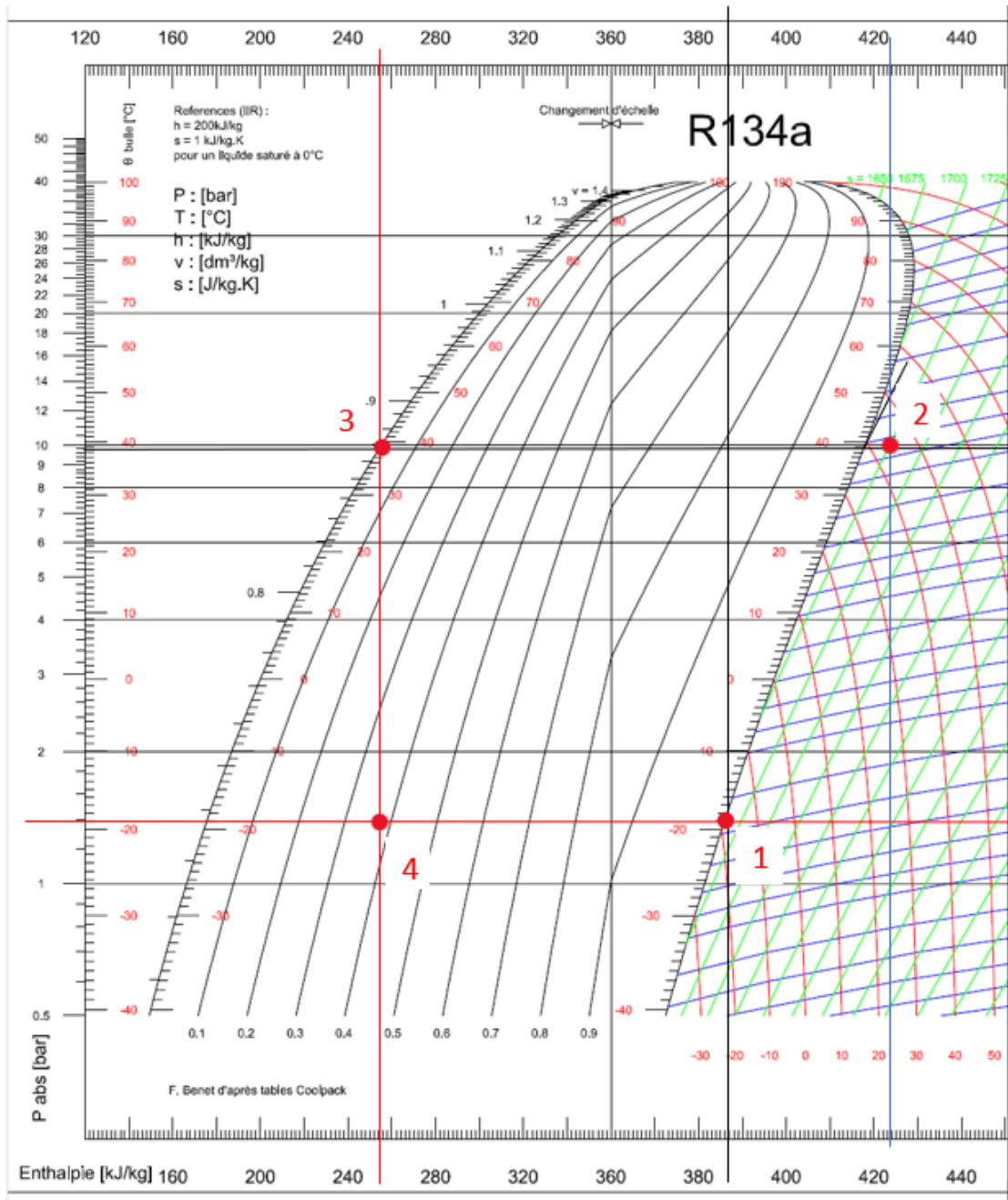

e.g. A refrigeration cycle uses refrigerant R-134a and operates between a low-side pressure of 0.14MPa and high side pressure of 1MPa. The refrigerant mass flow rate is 0.05kg/sec. find the cooling effect, work input and cop of this machine.

Solution:





From P-h diagram and table we find the enthalpies of each point as follows:

Point	P MPa	h kJ/sec
1 (table)	0.14	387
2 (chart)	1	424
3 (table)	1	256
4	0.14	256

Work input to compressor $W_c = h_2 - h_1 = 424 - 387 = 37$ kJ/kg.

Power input to the compressor = $m (h_2 - h_1) = 0.05 (424 - 387) = 1.85$ kW.

Refrigeration effect (Q_{evap}) = $h_1 - h_4 = 387 - 256 = 131$ kJ/kg.

Refrigeration effect in kW = $m (h_1 - h_4) = 0.05 (387 - 256) = 6.55$ kW.

$$COP = \frac{Q_{evap}}{W_{comp}} = \frac{131}{37} = 3.54$$

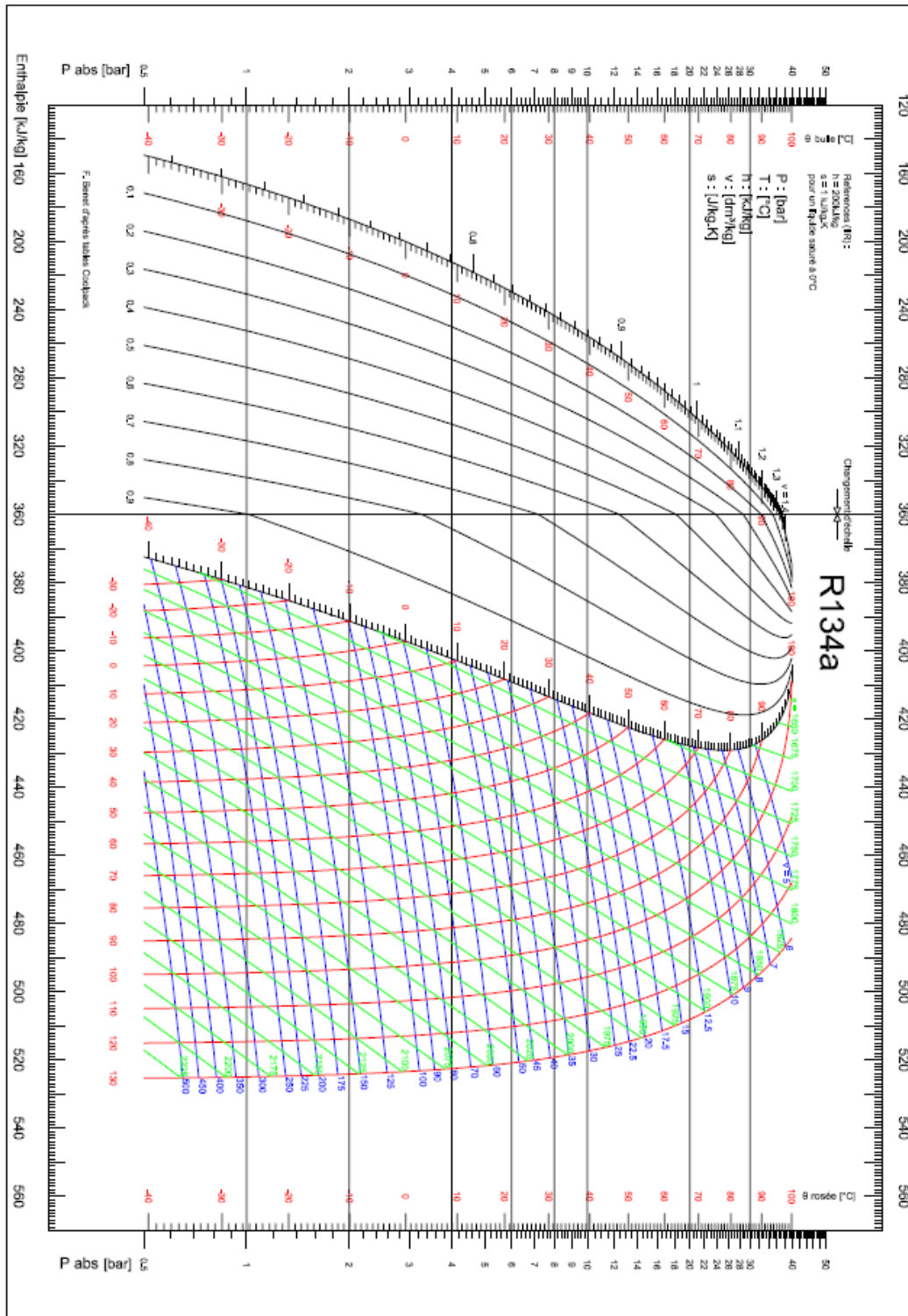



Tutorial sheet

1. the temperature in evaporator coil is -6°C and that in the condenser coil is 22°C . assuming that the machine operates on the reversed Carnot cycle. Calculate the COP the refrigeration effect per kW of input work, and the heat rejected to the condenser.
(9.54;9.54kW;10.4kW)
2. a Carnot refrigeration cycle absorbs heat at (-12°C) and rejects it at 40°C a- calculate the COP of this cycle d- If the cycle is absorbing 15 kW at (-12°C) temperature, how much power is required. C- if the Carnot heat pump operates between the same temperature, what is the performance factor d- what is the rate of heat rejection at 40°C if the heat pump absorbs 15 kW at the (-12°C) temperature.
(18kW)
3. in a standard vapour compression cycle using R-22 the evaporation temperature is (-5°C) and the condensing temperature is 30°C , calculate a-the work of compression b- the refrigeration effect c-the heat rejected in the condenser d- COP
(6.47)
4. a refrigeration system using R-22 is to have a refrigerating capacity of 80 kW. The cycle is standard vapour compression cycle in which the evaporation temperature is (-8°C) and the condensing temperature 42°C a- determine the volume flow of refrigerant measured in cubic meter per second at the inlet to the compressor. B- calculate the power required by the compressor. C-at the entrance to the evaporator what is the fraction of vapour in the mixture expressed both on mass basis and volume basis(0.292,0.971)
5. a refrigerant R-22 vapour compression system includes a liquid to suction heat exchanger in the system. The heat exchanger warms saturated vapour coming from evaporator from (-10°C) to 5°C with liquid which comes from the condenser at 30°C . the compression are isentropic in both cases below. A – calculate the COP of the system without the heat exchanger but with condensing temperature at 30°C and evaporator temperature of (-10°C) (5.46) b- calculate the COP with the heat exchanger (5.37) c- if the compressor is capable of pumping 12 lit/s measured at the compressor suction, what is the refrigeration capacity of the system without heat exchanger and with heat exchanger(30.3kW, 29.9kW)



Types of compressors:

As we seen before, the typical vapour compression refrigeration cycle consist of four major units, and they are compressor, condense, evaporator and expansion valve.

Compressors:

A compressor is the most important and often the costliest component (typically 30 to 40 percent of total cost) of any vapour compression refrigeration system. The function of a compressor is to raise the temperature of refrigerant vapour by rising pressure of the refrigerant to a level at which it can exchange heat with the ambient temperature and condenses by rejecting heat to the cooling medium in the condenser.

1. compressor classifications:

The compressors can be classified by different principles as follows:

1. Based on the working principle: two types of compressors are used in the vapour compression cycle namely:

1.1 Positive displacement compressors:

In positive displacement type compressors, compression is achieved by:

- trapping a refrigerant vapour into an enclosed space.
- reducing its volume.

Since a fixed amount of refrigerant is trapped each time, its pressure rises as its volume is reduced. When the pressure rises to a level that is slightly higher than the condensing pressure, then it is expelled from the enclosed space and a fresh charge of low-pressure refrigerant is drawn in and the cycle continues.

Since the flow of refrigerant to the compressor is not steady, the positive displacement type compressor is a *pulsating flow device*. However, since the operating speeds are normally very high the flow appears to be almost steady on macroscopic time scale. Since the flow is pulsating on a microscopic time scale, **positive displacement type compressors are prone to high wear, vibration and noise level**. Depending upon the construction, positive displacement type compressors used in refrigeration and air conditioning can be classified into:



- i. Reciprocating type.
- ii. Screw type.
- iii. Scroll type.
- iv. Rotary compressor.

1.2 Dynamic compressors

In dynamic compressors,

- the pressure rise of refrigerant is achieved by imparting kinetic energy to a steadily flowing stream of refrigerant by a rotating mechanical element.
- then converting into pressure as the refrigerant flows through a diverging passage.

Unlike positive displacement type, the dynamic type compressors are steady flow devices, hence are subjected to less wear and vibration.

2. Based on arrangement of compressor motor or external drive:

2.1 Open type:

The rotating shaft of the compressor extends through a seal in the crankcase for an external drive.

The external drive may be an electric motor or an engine (e.g. diesel engine). The compressor may be belt driven or gear driven.

Open type compressors are normally used in a medium to large capacity refrigeration system for all refrigerants and for ammonia.

Open type compressors are characterized by:

- high efficiency,
- flexibility,
- better compressor cooling and serviceability.

However, since the shaft has to extend through the seal, refrigerant leakage from the system cannot be eliminated completely.

Hence refrigeration systems using open type compressors require a refrigerant reservoir to take care of the refrigerant leakage for some time, and then regular maintenance for charging the system with refrigerant, changing of seals, gaskets etc. Figure 1 shows the open type compressors.



2.2 Hermetic type: In hermetic compressors, the motor and the compressor are enclosed in the same housing to prevent refrigerant leakage. The housing has welded connections for refrigerant inlet and outlet and for power input socket. The compressor gets heated-up due to friction and also due to temperature rise of the vapor during compression. In Open type, both the compressor and the motor normally reject heat to the surrounding air for efficient operation.

In hermetic compressors heat cannot be rejected to the surrounding air since both are enclosed in a shell. Hence, **the cold suction gas is made to flow over the motor and the compressor before entering the compressor. This keeps the motor cool.** The cooling rate depends upon the flow rate of the refrigerant, its temperature and the thermal properties of the refrigerant. If flow rate is not sufficient and/or if the temperature is not low enough the insulation on the winding of the motor can burn out and short-circuiting may occur. Hence, hermetically sealed compressors give satisfactory and safe performance over a very narrow range of design temperature and should not be used for off-design conditions. The COP of the hermetic compressor based systems is lower than that of the open compressor-based systems **since a part of the refrigeration effect is lost in cooling the motor and the compressor.** However, hermetic compressors are almost universally **used in small systems such as domestic refrigerators, water coolers, air conditioners** etc, where efficiency is not as important as customer convenience (due to absence of continuous maintenance). In addition to this, the use of hermetic compressors is ideal in systems, **which use capillary tubes as expansion devices and are critically charged systems.** Hermetic compressors are normally not serviceable. **They are not very flexible as it is difficult to vary their speed to control the cooling capacity.** Figure 2 shows the hermetic compressor.



2.3 Semi-hermetic type: In some (usually larger) hermetic units, the cylinder head is usually removable so that the valves and the piston can be serviced. This type of unit is called a semi-hermetic (or semi sealed) compressor, figure 3 shows the semi-hermetic compressor.

Figure 4 shows the classifications of Refrigeration compressors

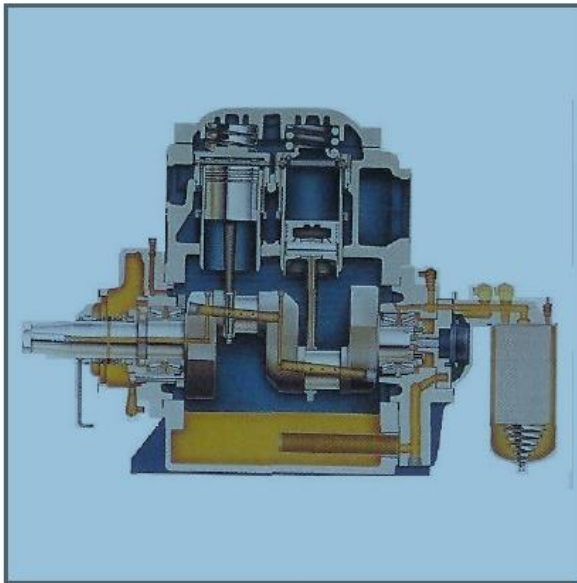

Figure 1 open type compressor

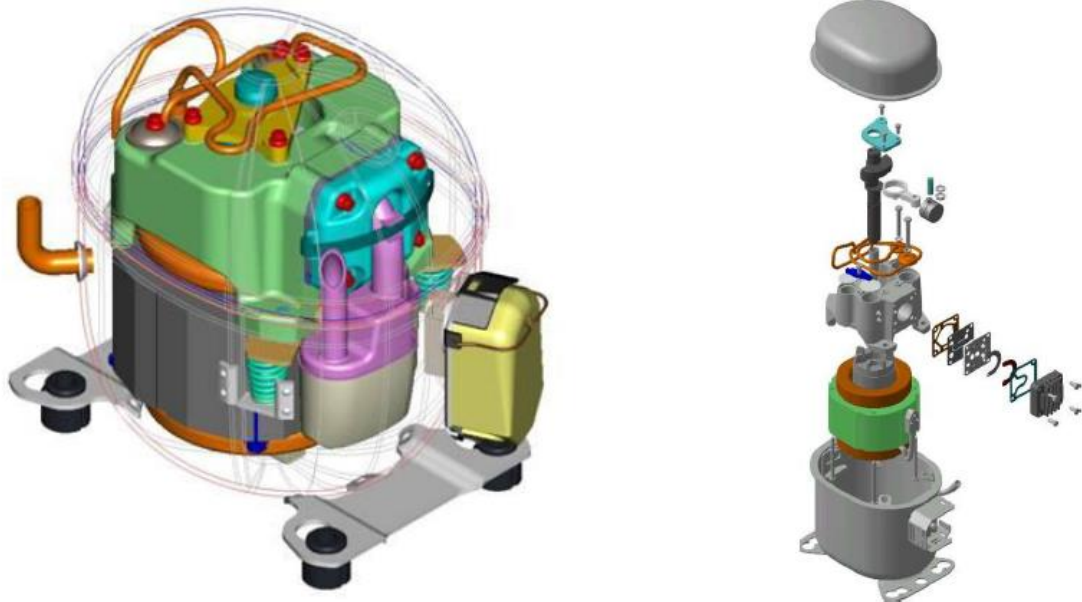

Figure 2 hermetic compressor

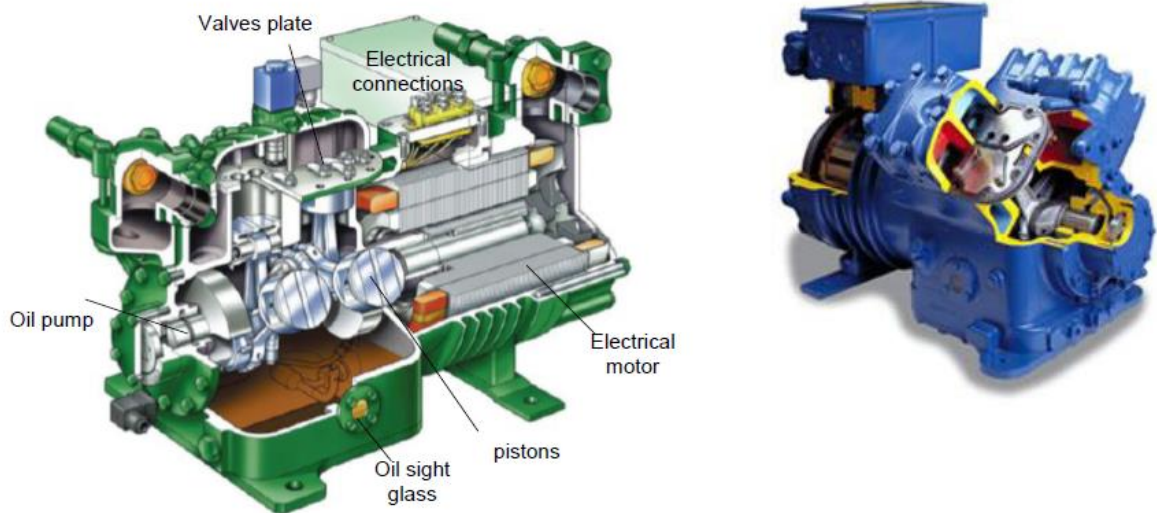

Figure 3 semi-hermetic compressor

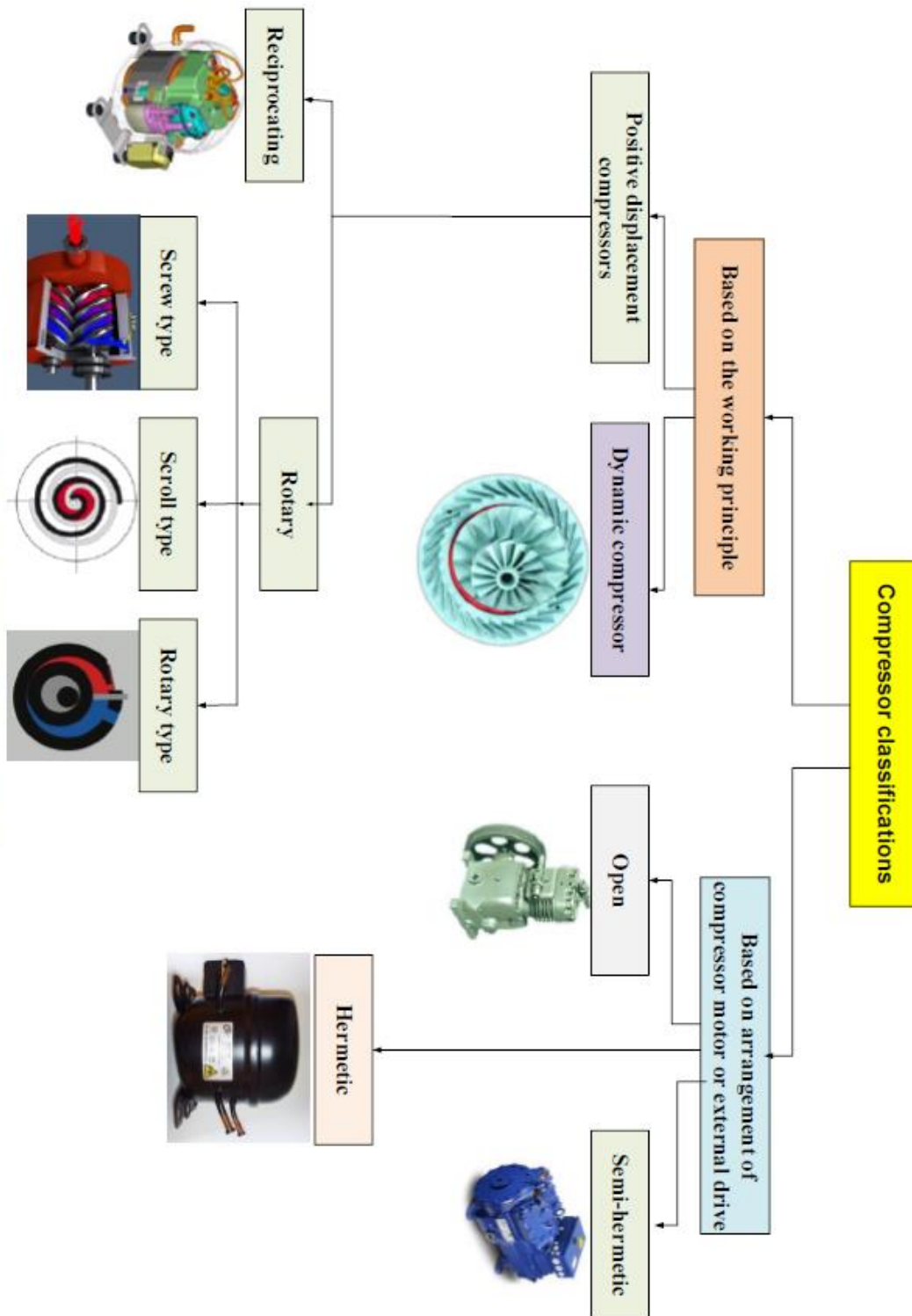

Figure 4 compressor classifications



3. Reciprocating compressor

The reciprocating compressor (piston type) is very widely used, being adaptable in size, number of cylinders, speed and method of drive. It works on the two-stroke cycle. Automatic pressure actuated suction and discharge valves are used as shown in Figure 5. As the piston descends on the suction stroke, the suction valve opens to admit gas from the evaporator. At the bottom of the stroke, this valve will close again as the compression stroke begins. When the cylinder pressure becomes higher than that in the discharge pipe, the discharge valve opens and the compressed gas passes to the condenser. Gas left in the clearance at the top of the stroke must re-expand before a fresh charge can enter the cylinder, see Figure 5e. The suction valve will not open until the cylinder pressure is lower than the suction pressure. A larger re-expansion or *clearance volume* means the piston must travel further down the cylinder before the pressure falls below suction pressure. The further the piston travel, without the valve opening, the higher the losses.

- a- Reciprocating compressor.
- b- Piston moves down open suction valve.
- c- Piston moves up closed suction valve.
- d- Piston moves up compressed vapour.
- e- Open discharge valve.
- f- Piston moves down.

Figure 5 show how reciprocating compressor works.

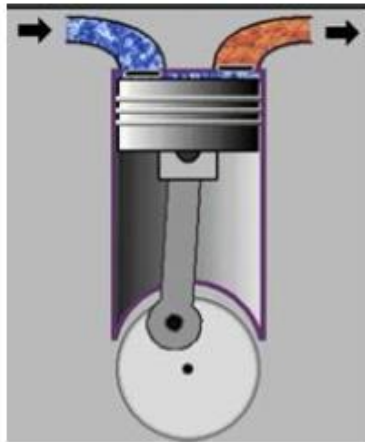

a- Reciprocating compressor

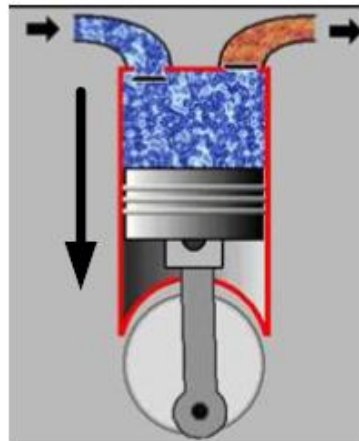

b- Piston moves down open suction valve

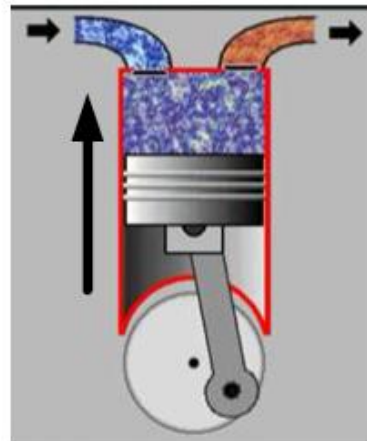

c- Piston moves up closed suction valve



d- Piston moves up compressed vapour

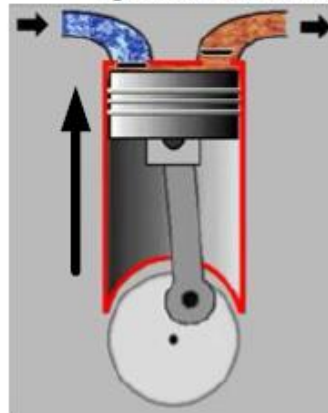

e- Open discharge valve

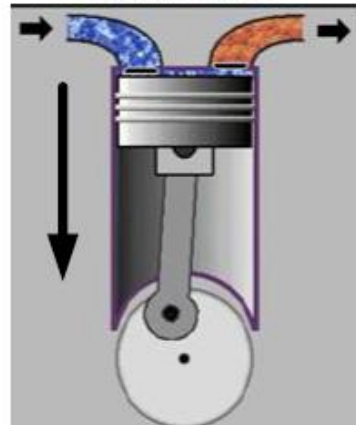

f- Piston moves down

Figure 5 how reciprocating compressor works