



Al-Mustaqbal University

College of Engineering

Department of Biomedical Engineering

Stage: 4th

Microcontroller

2025-2026

Lecture ():

PC Interfacing
Fourth Level
Lecture

Types of ADC

Types of A/D Converters

- Flash ADC
- Delta-Sigma ADC
- Dual Slope (integrating) ADC
- Successive Approximation ADC

1. Flash A/D Converter

Fundamental Components

Resistors use the resistors to form a ladder voltage divider, which divides the reference voltage into equal intervals.

Comparators Consists of a series of comparators, which comparing the input signal to a unique reference voltage.

Priority encoder the comparator outputs connect to the inputs of a priority encoder circuit, which produces a binary output.

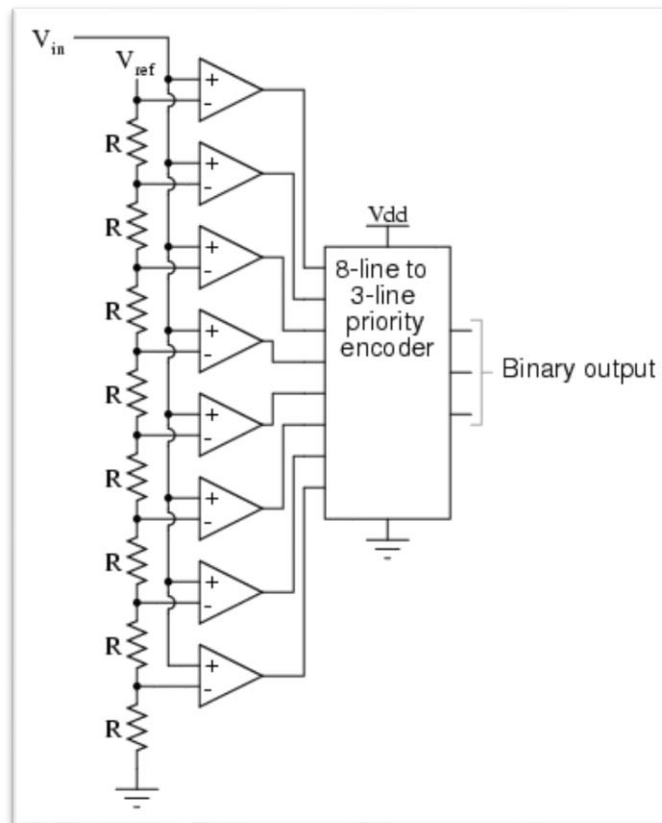

How does it work?

- Uses the comparators to determine in which the input voltage V_{in} is exceed or not the V_{ref} .
- When the analog input voltage exceeds the reference voltage at each comparator, the comparator outputs will sequentially saturate to a high state.
- The priority encoder generates a binary number based on the highest-order active input, ignoring all other active inputs.

Advantages and Disadvantages

- Simplest in terms of operational theory, most efficient in terms of speed (very fast).
- Lower resolution, Expensive, for each additional output bit, the number of comparators is increase.

2. Sigma Delta ADC

Main Components

- Resistors
- Integrator
- Capacitor
- Comparators
- Control Logic

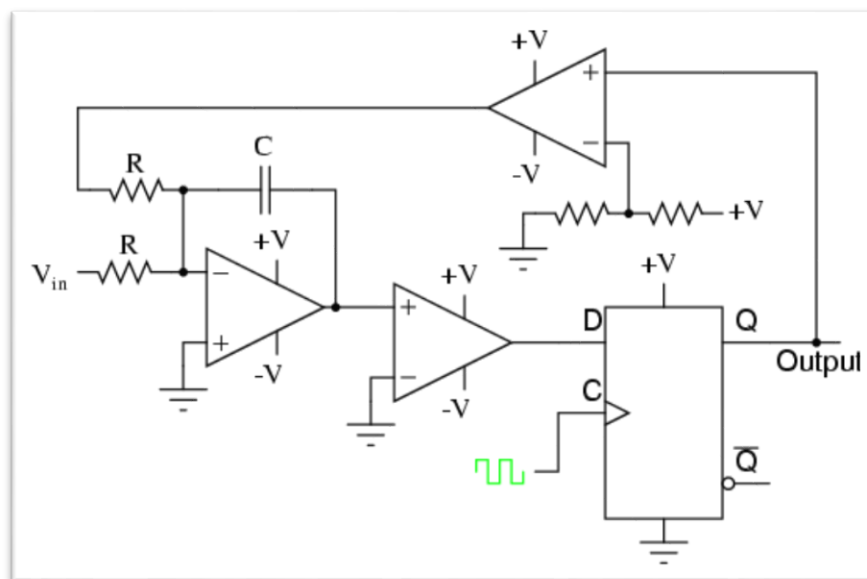

How does it work?

- Input is over sampled, and goes to integrator.
- The integration is then compared to ground.
- Iterates and produces a serial bit stream.
- Output is a serial bit stream which is proportional to V_{in} .

Advantages and Disadvantages

- High resolution.
- Slow due to oversampling.

3. Dual Slope Converter

Fundamental components

- Integrator
- Electronically Controlled Switches
- Counter
- Clock
- Control Logic
- Comparator

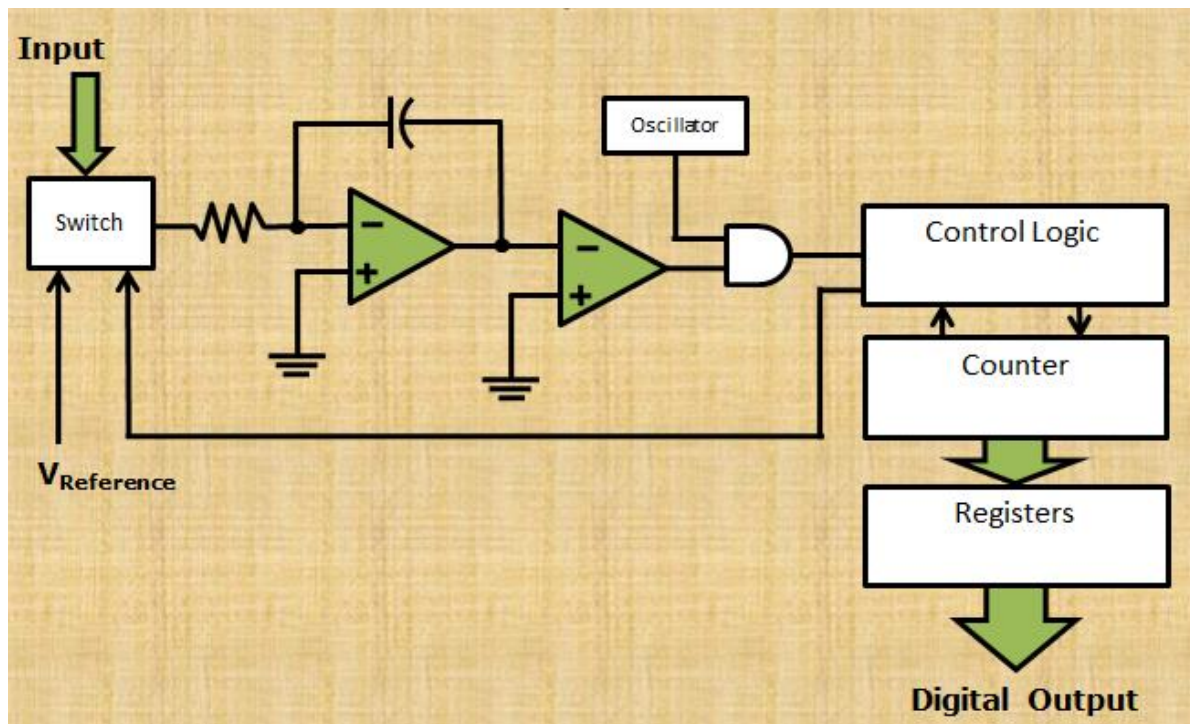

The Dual Slope ADC functions in this manner:

- When an analog value is applied, the capacitor begins to charge in a linear manner and the oscillator passes to the counter.
- The counter continues to count until it reaches a predetermined value. Once this value is reached the count stops and the counter is reset. The control logic switches the input to the first comparator to a reference voltage, providing a discharge path for the capacitor.
- As the capacitor discharges the counter counts.
- When the capacitor voltage reaches the reference voltage the count stops and the value is stored in the register.

Advantages and Disadvantages

- High Accuracy.
- Slow, Cost.

4. Successive Approximation ADC

- Much faster than the Dual Slope.
- A comparator and a DAC are used in the process.
- A Successive Approximation Register (SAR) is added to the circuit
- Instead of counting up in binary sequence, this register counts by trying all values of bits starting with the MSB and finishing at the LSB.
- The register monitors the comparators output to see if the binary count is greater or less than the analog signal input and adjusts the bits accordingly.

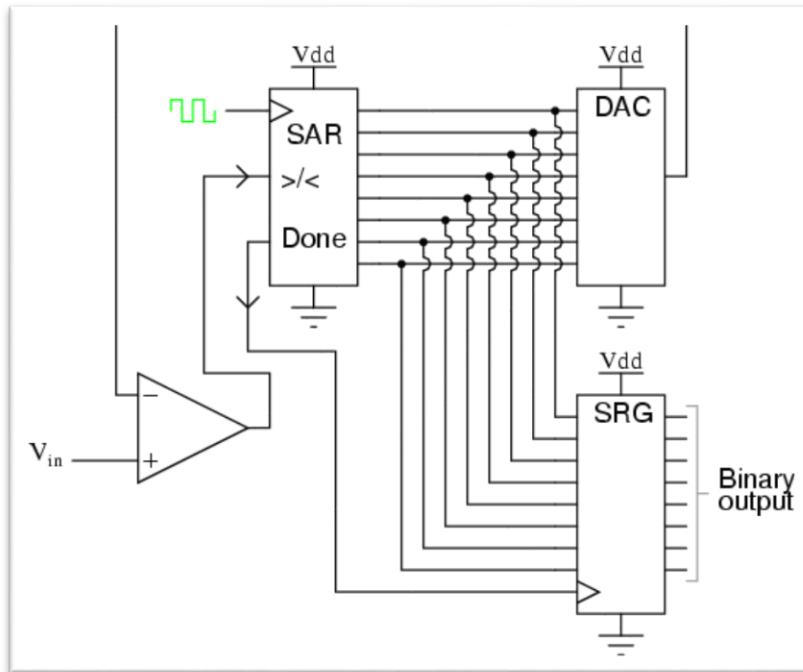

Advantages and Disadvantages

- Capable of high speed and reliable, medium accuracy compared to other ADC types, Good tradeoff between speed and cost.
- Higher resolution successive approximation ADC's will be slower.

Example

10 bit ADC, $V_{in} = 0.6$ volts (from analog device), $V_{ref} = 1$ volts, Find the digital value of V_{in} ?

Solu:

- MSB (bit 9)
 - Divided V_{ref} by 2
 - Compare $V_{ref}/2$ with V_{in}
 - If V_{in} is greater than $V_{ref}/2$, turn MSB on (1)
 - If V_{in} is less than $V_{ref}/2$, turn MSB off (0)
 - $V_{in} = 0.6V$ and $V = 0.5$
 - Since $V_{in} > V$, MSB = 1 (on)

1									
---	--	--	--	--	--	--	--	--	--

- Next Calculate MSB-1 (bit 8)
 - Compare $V_{in} = 0.6$ V to $V = V_{ref}/2 + V_{ref}/4 = 0.5 + 0.25 = 0.75V$
 - Since $0.6 < 0.75$, MSB is turned off
- Calculate MSB-2 (bit 7)
 - Go back to the last voltage that caused it to be turned on (Bit 9) and add it to $V_{ref}/8$, and compare with V_{in}
 - Compare V_{in} with $(0.5 + V_{ref}/8) = 0.625$
 - Since $0.6 < 0.625$, MSB is turned off

1	0	0							
---	---	---	--	--	--	--	--	--	--

- Calculate the state of MSB-3 (bit 6)
 - Go to the last bit that caused it to be turned on (In this case MSB-1) and add it to $V_{ref}/16$, and compare it to V_{in}
 - Compare V_{in} to $V = 0.5 + V_{ref}/16 = 0.5625$
 - Since $0.6 > 0.5625$, MSB-3=1 (turned on)

MSB	MSB-1	MSB-2	MSB-3	...					
1	0	0	1						

- This process continues for all the remaining bits.

•Digital Results:

MSB	MSB-1	MSB-2	MSB-3	...					LSB
1	0	0	1	1	0	0	1	1	0

•Results: $\frac{1}{2} + \frac{1}{16} + \frac{1}{32} + \frac{1}{256} + \frac{1}{512} = .599609375 \text{ V}$

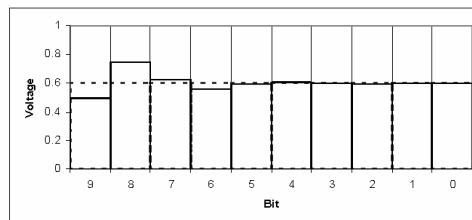

ADC Specifications:

- Conversion time
- Resolution
- Accuracy
- Linearity
- Missing code

ADC Errors due to Noise and Aliasing.

How to choose the ADC according to the resolution?

Two ways for find the resolution needed in ADC, first way is to find the **dynamic range** of input signal and to choose the number of bits based on this.

$$N \geq \ln(V_{max}/V_{noise}) \text{ --- dynamic range (stage) (sensor)}$$

Another way to choose the number of bits is based on the **resolution required** in input signal.

$$N \geq \ln(S_{max}/S_{noise}) \text{ --- required resolutions (stage before ADC) (transducer)}$$

Example

A transducer is to be used to find the temperature over a range of 0 to 100 C. we are required to read and display the temperature to a resolution of +- 1 C. the transducer produces a voltage from 0 to 3v over this temperature range with +-3mv noise. Specify the number of bits in ADC: a) Based on dynamic range. b) Based on required resolutions.

- **Conversion time** is the time required to complete a conversion of the input signal, in other words it's the time it takes for an analog-to-digital conversion.

$$F_{\max} = \frac{1}{2 * \text{Conversion time}}$$

Ex:

1. An ADC has a conversion time of 100 μ s. what is the maximum frequency that can be converted?
2. A 1 Khz sinusoidal signal to be digitized using 8-bit ADC. Find the conversion time that can be used?

- **Resolution** is the number of bits used for conversion (8 bits, 12 bits, ...)

$$\text{resolution} = \frac{\text{full Scale Signal}}{2^n}$$

Ex:

An 8-bits ADC is used to digitize a five volt (5v) full scale signal. What is the resolution?

- **Quantization error** is defined as the difference between the actual analog input and the digital representation of that value.

$$\text{Maximum Quantization } (q_{\max}) = \frac{A}{2^{n+1}}$$

$$\text{Average Quantization } (q_{\text{av}}) = \frac{A}{2^{n+2}}$$

Where A is the amplitude and n is the number of bits.

Ex:

An analog signal of amplitude 12v is sampled with an 8bit ADC; calculate the maximum and average quantization error?