



Lecture Four

Standard Forms of Boolean Expressions

All Boolean expressions, regardless of their form, can be converted into either of two standard forms: the sum-of-products form or the product-of-sums form.

The Sum-of-Products (SOP) Form

When two or more product terms are summed by Boolean addition, the resulting expression is a sum of products (SOP). Some examples are

$$AB + ABC$$
$$ABC + CDE + \overline{BCD}$$
$$\overline{AB} + \overline{ABC} + AC$$

Also, an SOP expression can contain a single-variable term, as in $A + \overline{A}BC + BCD$
SOP expression can have the term $\overline{A}\overline{B}\overline{C}$ but not \overline{ABC} .

Domain of a Boolean Expression

The domain of the expression $\overline{A}B + A\overline{B}C$ is the set of variables A, B, C , and the domain of the expression $ABC\overline{C} + C\overline{D}E + \overline{BCD}$ is the set of variables A, B, C, D, E .

AND/OR Implementation of an SOP Expression

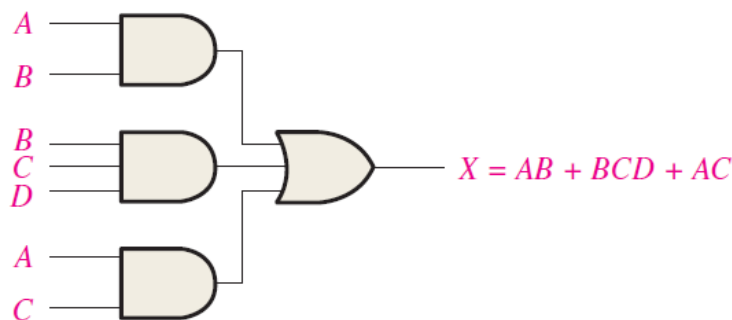



NAND/NAND Implementation of an SOP Expression

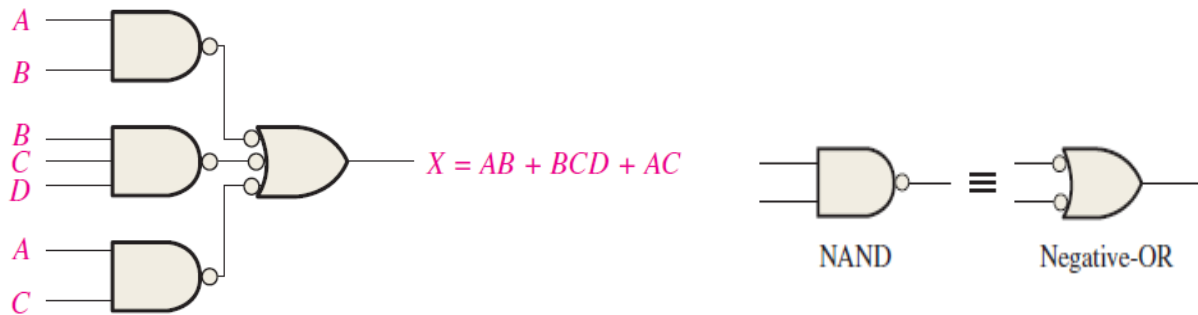

Conversion of a General Expression to SOP Form

For example, the expression $A(B + CD)$ can be converted to SOP form by applying the distributive law: $A(B + CD) = AB + ACD$

Example

Convert each of the following Boolean expressions to SOP form:

- (a) $AB + B(CD + EF)$ (b) $(A + B)(B + C + D)$ (c) $\overline{\overline{(A + B)} + C}$

Solution

(a) $AB + B(CD + EF) = AB + BCD + BEF$

(b) $(A + B)(B + C + D) = AB + AC + AD + BB + BC + BD$

(c) $\overline{\overline{(A + B)} + C} = \overline{\overline{(A + B)}\overline{C}} = (A + B)\overline{C} = A\overline{C} + B\overline{C}$

Related Problem

Convert $\overline{A}B\overline{C} + (A + \overline{B})(B + \overline{C} + A\overline{B})$ to SOP form.



The Standard SOP Form

So far, you have seen SOP expressions in which some of the product terms do not contain all of the variables in the domain of the expression. For example, the expression $\overline{A}BC + \overline{A}BD + \overline{A}BCD$ has a domain made up of the variables $A, B, C,$ and D . However, notice that the complete set of variables in the domain is not represented in the first two terms of the expression; that is, D or \overline{D} is missing from the first term and C or \overline{C} is missing from the second term.

Example

Convert the following Boolean expression into **standard** SOP form:

$$\overline{A}BC + \overline{A}\overline{B} + ABC\overline{D}$$

Solution

The domain of this SOP expression is A, B, C, D . Take one term at a time. The first term, $\overline{A}BC$, is missing variable D or \overline{D} , so multiply the first term by $D + \overline{D}$ as follows:

$$\overline{A}BC = \overline{A}BC(D + \overline{D}) = \overline{A}BCD + \overline{A}BC\overline{D}$$

In this case, two standard product terms are the result.

The second term, $\overline{A}\overline{B}$, is missing variables C or \overline{C} and D or \overline{D} , so first multiply the second term by $C + \overline{C}$ as follows:

$$\overline{A}\overline{B} = \overline{A}\overline{B}(C + \overline{C}) = \overline{A}\overline{B}C + \overline{A}\overline{B}\overline{C}$$

The two resulting terms are missing variable D or \overline{D} , so multiply both terms by $D + \overline{D}$ as follows:

$$\begin{aligned}\overline{A}\overline{B} &= \overline{A}\overline{B}C + \overline{A}\overline{B}\overline{C} = \overline{A}\overline{B}C(D + \overline{D}) + \overline{A}\overline{B}\overline{C}(D + \overline{D}) \\ &= \overline{A}\overline{B}CD + \overline{A}\overline{B}C\overline{D} + \overline{A}\overline{B}\overline{C}D + \overline{A}\overline{B}\overline{C}\overline{D}\end{aligned}$$

In this case, four standard product terms are the result.

The third term, $ABC\overline{D}$, is already in standard form. The complete standard SOP form of the original expression is as follows:

$$\overline{A}BC + \overline{A}\overline{B} + ABC\overline{D} = \overline{A}BCD + \overline{A}BC\overline{D} + \overline{A}\overline{B}CD + \overline{A}\overline{B}C\overline{D} + \overline{A}\overline{B}\overline{C}D + \overline{A}\overline{B}\overline{C}\overline{D} + ABC\overline{D}$$



The Product-of-Sums (POS) Form

When two or more sum terms are multiplied, the resulting expression is a **product-of-sum (POS)**. Some examples are

$$\begin{aligned} &(\bar{A} + B)(A + \bar{B} + C) \\ &(\bar{A} + \bar{B} + \bar{C})(C + \bar{D} + E)(\bar{B} + C + D) \\ &(A + B)(A + \bar{B} + C)(\bar{A} + C) \end{aligned}$$

For example, a POS expression can have the term $\bar{A} + \bar{B} + \bar{C}$ but not $\overline{A + B + C}$.

Implementation of a POS Expression

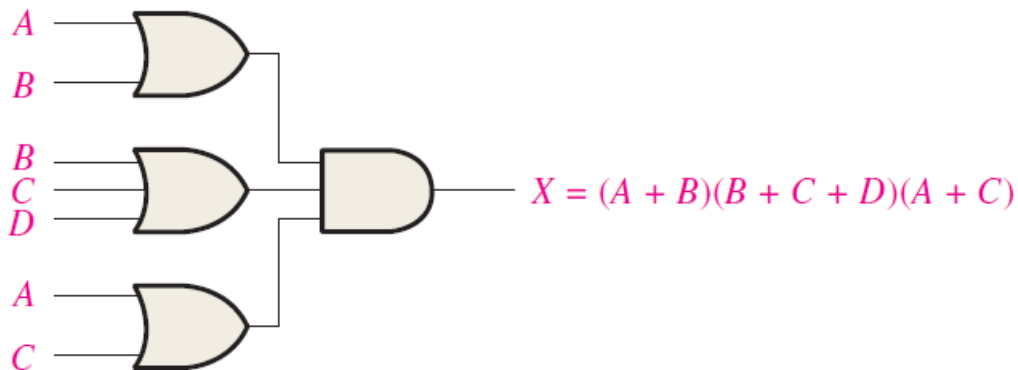

The Standard POS Form

So far, you have seen POS expressions in which some of the sum terms do not contain all of the variables in the domain of the expression. For example, the expression

$$(A + \bar{B} + C)(A + B + \bar{D})(A + \bar{B} + \bar{C} + D)$$

has a domain made up of the variables A , B , C , and D . Notice that the complete set of variables in the domain is not represented in the first two terms of the expression; that is, D or \bar{D} is missing from the first term and C or \bar{C} is missing from the second term.



Converting a Sum Term to Standard POS

Example:

Convert the following Boolean expression into standard POS form:

$$(A + \bar{B} + C)(\bar{B} + C + \bar{D})(A + \bar{B} + \bar{C} + D)$$

Solution

The domain of this POS expression is A, B, C, D . Take one term at a time. The first term, $A + \bar{B} + C$, is missing variable D or \bar{D} , so add $D\bar{D}$ and apply rule 12 as follows:

$$A + \bar{B} + C = A + \bar{B} + C + D\bar{D} = (A + \bar{B} + C + D)(A + \bar{B} + C + \bar{D})$$

The second term, $\bar{B} + C + \bar{D}$, is missing variable A or \bar{A} , so add $A\bar{A}$ and apply rule 12 as follows:

$$\bar{B} + C + \bar{D} = \bar{B} + C + \bar{D} + A\bar{A} = (A + \bar{B} + C + \bar{D})(\bar{A} + \bar{B} + C + \bar{D})$$

The third term, $A + \bar{B} + \bar{C} + D$, is already in standard form. The standard POS form of the original expression is as follows:

$$(A + \bar{B} + C)(\bar{B} + C + \bar{D})(A + \bar{B} + \bar{C} + D) = \\ (A + \bar{B} + C + D)(A + \bar{B} + C + \bar{D})(A + \bar{B} + C + \bar{D})(\bar{A} + \bar{B} + C + \bar{D})(A + \bar{B} + \bar{C} + D)$$

Binary Representation of a Standard Sum Term

A POS expression is equal to 0 only if one or more of the sum terms in the expression is equal to 0.

Example

Determine the binary values of the variables for which the following standard POS expression is equal to 0:



Example

Determine the binary values of the variables for which the following standard POS expression is equal to 0:

$$(A + B + C + D)(A + \bar{B} + \bar{C} + D)(\bar{A} + \bar{B} + \bar{C} + \bar{D})$$

Solution

The term $A + B + C + D$ is equal to 0 when $A = 0$, $B = 0$, $C = 0$, and $D = 0$.

$$A + B + C + D = 0 + 0 + 0 + 0 = 0$$

The term $A + \bar{B} + \bar{C} + D$ is equal to 0 when $A = 0$, $B = 1$, $C = 1$, and $D = 0$.

$$A + \bar{B} + \bar{C} + D = 0 + \bar{1} + \bar{1} + 0 = 0 + 0 + 0 + 0 = 0$$

The term $\bar{A} + \bar{B} + \bar{C} + \bar{D}$ is equal to 0 when $A = 1$, $B = 1$, $C = 1$, and $D = 1$.

$$\bar{A} + \bar{B} + \bar{C} + \bar{D} = \bar{1} + \bar{1} + \bar{1} + \bar{1} = 0 + 0 + 0 + 0 = 0$$

The POS expression equals 0 when any of the three sum terms equals 0.

Converting Standard SOP to Standard POS

To convert standard SOP to standard POS, the following steps are taken:

Step 1: Evaluate each product term in the SOP expression. That is, determine the binary numbers that represent the product terms.

Step 2: Determine all of the binary numbers not included in the evaluation in Step 1.

Step 3: Write the equivalent sum term for each binary number from Step 2 and express in POS form.



Example

Convert the following SOP expression to an equivalent POS expression:

$$\overline{A}\overline{B}\overline{C} + \overline{A}B\overline{C} + \overline{A}BC + A\overline{B}\overline{C} + ABC$$

Solution

The evaluation is as follows:

$$000 + 010 + 011 + 101 + 111$$

Since there are three variables in the domain of this expression, there are a total of eight (2^3) possible combinations. The SOP expression contains five of these combinations, so the POS must contain the other three which are 001, 100, and 110. Remember, these are the binary values that make the sum term 0. The equivalent POS expression is

$$(A + B + \overline{C})(\overline{A} + B + C)(\overline{A} + \overline{B} + C)$$

Boolean Expressions and Truth Tables

Example

Develop a truth table for the standard SOP expression $\overline{A}\overline{B}\overline{C} + \overline{A}B\overline{C} + ABC$.

Solution

The binary values that make the product terms in the expressions equal to 1 are

Inputs			Output	Product Term
A	B	C	X	
0	0	0	0	
0	0	1	1	$\overline{A}\overline{B}C$
0	1	0	0	
0	1	1	0	
1	0	0	1	$A\overline{B}\overline{C}$
1	0	1	0	
1	1	0	0	
1	1	1	1	ABC



Converting POS Expressions to Truth Table Format

Example:

Determine the truth table for the following standard POS expression:

$$(A + B + C)(A + \bar{B} + C)(A + \bar{B} + \bar{C})(\bar{A} + B + \bar{C})(\bar{A} + \bar{B} + C)$$

Solution

Inputs			Output	Sum Term
A	B	C	X	
0	0	0	0	$(A + B + C)$
0	0	1	1	
0	1	0	0	$(A + \bar{B} + C)$
0	1	1	0	$(A + \bar{B} + \bar{C})$
1	0	0	1	
1	0	1	0	$(\bar{A} + B + \bar{C})$
1	1	0	0	$(\bar{A} + \bar{B} + C)$
1	1	1	1	

Determining Standard Expressions from a Truth Table

Example

From the truth table determine the standard SOP expression and the equivalent standard POS expression.

Inputs			Output
A	B	C	X
0	0	0	0
0	0	1	0
0	1	0	0
0	1	1	1
1	0	0	1
1	0	1	0
1	1	0	1
1	1	1	1



Solution

There are four 1s in the output column and the corresponding binary values are 011, 100, 110, and 111. Convert these binary values to product terms as follows:

$$011 \longrightarrow \bar{A}BC$$

$$100 \longrightarrow A\bar{B}\bar{C}$$

$$110 \longrightarrow AB\bar{C}$$

$$111 \longrightarrow ABC$$

The resulting standard SOP expression for the output X is

$$X = \bar{A}BC + A\bar{B}\bar{C} + AB\bar{C} + ABC$$

For the POS expression, the output is 0 for binary values 000, 001, 010, and 101. Convert these binary values to sum terms as follows:

$$000 \longrightarrow A + B + C$$

$$001 \longrightarrow A + B + \bar{C}$$

$$010 \longrightarrow A + \bar{B} + C$$

$$101 \longrightarrow \bar{A} + B + \bar{C}$$

The resulting standard POS expression for the output X is

$$X = (A + B + C)(A + B + \bar{C})(A + \bar{B} + C)(\bar{A} + B + \bar{C})$$



The Karnaugh Map

A Karnaugh map provides a systematic method for simplifying Boolean expressions and, if properly used, will produce the simplest SOP or POS expression possible, known as the minimum expression

Karnaugh Map SOP Minimization

When an SOP expression is completely mapped, there will be several **1s** on the Karnaugh map equal to the number of product terms in the standard SOP expression. The cells that do not have a 1 are the cells for which the expression is 0. **Usually, when working with SOP expressions, the 0s are left off the map.**

Mapping a Standard SOP Expression

Example

Map the following standard SOP expression on a Karnaugh map:

$$\bar{A}\bar{B}C + \bar{A}B\bar{C} + A\bar{B}\bar{C} + ABC$$

Solution

	\bar{C}	C
$\bar{A}.\bar{B}$		1
$\bar{A}.B$	1	
A.B	1	1
A. \bar{B}		



Example

Map the following standard SOP expression on a Karnaugh map:

$$\overline{A}\overline{B}CD + \overline{A}B\overline{C}\overline{D} + A\overline{B}\overline{C}D + ABCD + A\overline{B}C\overline{D} + \overline{A}B\overline{C}D + A\overline{B}C\overline{D}$$

Solution

	$\overline{C}.\overline{D}$	$\overline{C}.D$	$C.D$	$C.\overline{D}$
$\overline{A}.\overline{B}$		1	1	
$\overline{A}.B$	1			
$A.B$	1	1	1	
$A.\overline{B}$				1

Mapping a Nonstandard SOP Expression

Assume that one of the product terms in a 3-variable expression is B (*remember that a single variable counts as a product term in an SOP expression*). This term can be expanded numerically to standard form as follows. Write the binary value of the variable; then attach all possible values for the missing variables A and C as follows:

B
010
011
110
111



Example: Map the following SOP expression on a Karnaugh map $\bar{A} + A\bar{B} + ABC\bar{C}$.

Solution

The SOP expression is not in standard form because each product term does not have three variables. The first term is missing two variables, the second term is missing one variable, and the third term is standard. First, expand the terms numerically as follows

$$\begin{array}{l} \bar{A} + A\bar{B} + ABC\bar{C} \\ 000 \quad 100 \quad 110 \\ 001 \quad 101 \\ 010 \\ 011 \end{array}$$

		C	0	1
AB	00		1	1
	01		1	1
	11		1	
	10		1	1

Example 2

Map the following SOP expression on a Karnaugh map:

$$\bar{B}\bar{C} + A\bar{B} + ABC\bar{C} + A\bar{B}C\bar{D} + \bar{A}\bar{B}C\bar{D} + A\bar{B}C\bar{D}$$

Solution

$$\begin{array}{l} \bar{B}\bar{C} + A\bar{B} + ABC\bar{C} + A\bar{B}C\bar{D} + \bar{A}\bar{B}C\bar{D} + A\bar{B}C\bar{D} \\ 0000 \quad 1000 \quad 1100 \quad 1010 \quad 0001 \quad 1011 \\ 0001 \quad 1001 \quad 1101 \\ 1000 \quad 1010 \\ 1001 \quad 1011 \end{array}$$

		CD	00	01	11	10
AB	00		1	1		
	01					
	11		1	1		
	10		1	1	1	1

Karnaugh Map Simplification of SOP Expressions

Example

Group the 1s in each of the Karnaugh maps in Figure below

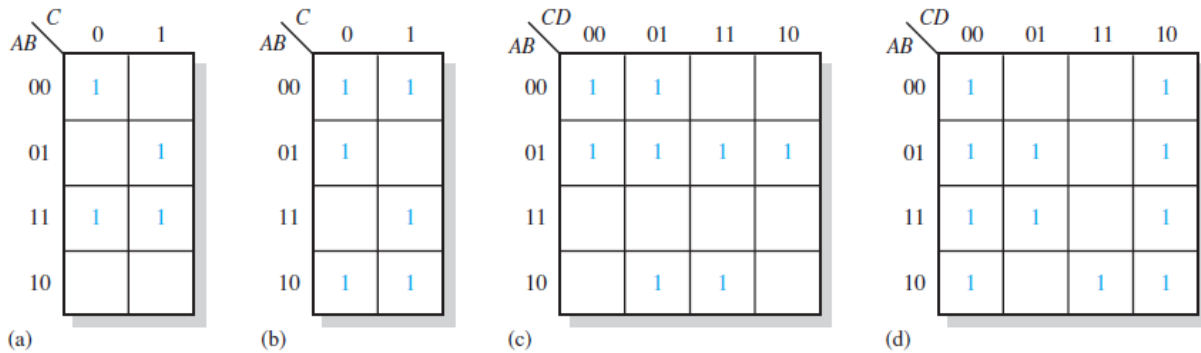

Solution

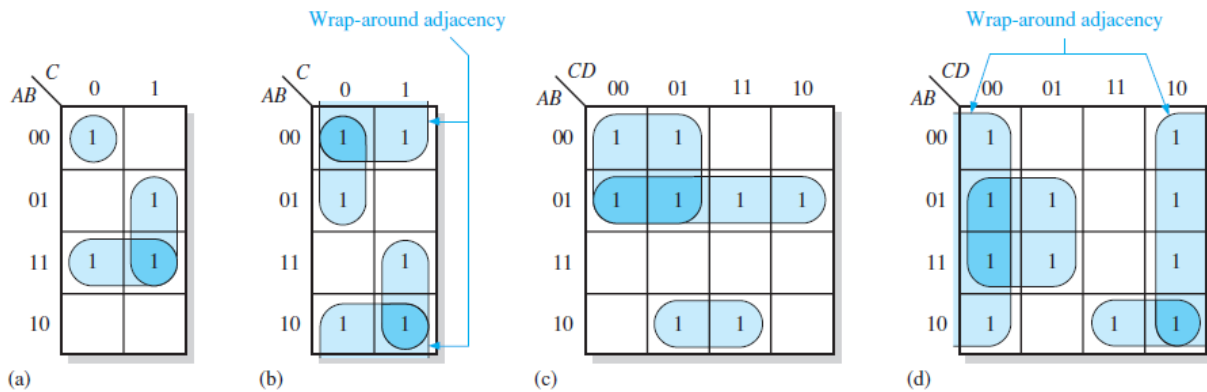

Example 2

Determine the product terms for the Karnaugh map in Figure below and write the resulting minimum SOP expression

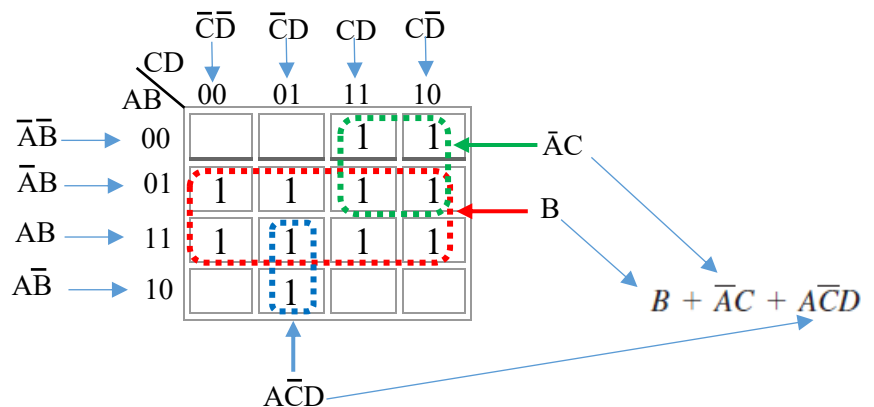

Example 3

Determine the product terms for each of the Karnaugh maps in Figure below and write the resulting minimum SOP expression

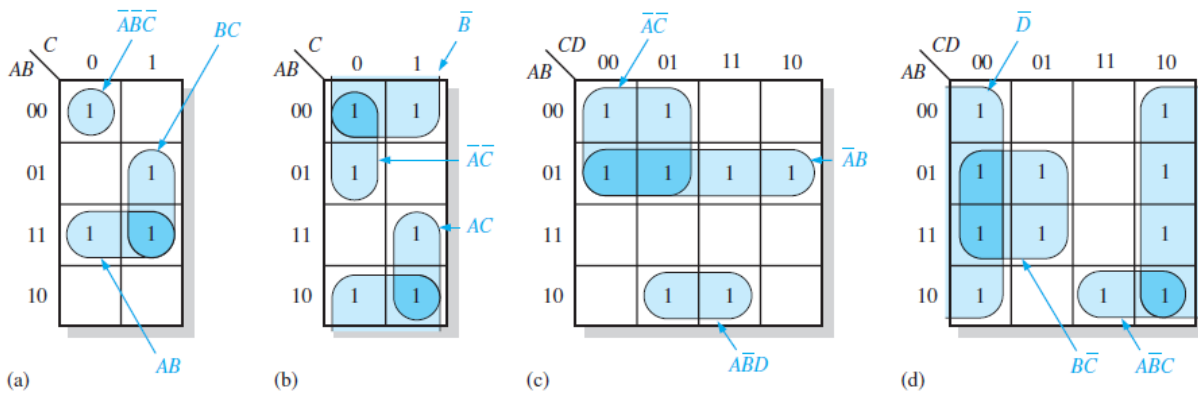

Solution

- (a) $AB + BC + \overline{A}\overline{B}\overline{C}$
- (b) $\overline{B} + \overline{A}\overline{C} + AC$
- (c) $\overline{A}\overline{B} + \overline{A}\overline{C} + A\overline{B}\overline{D}$
- (d) $\overline{D} + \overline{A}\overline{B}\overline{C} + \overline{B}\overline{C}$

Example 4

Use a Karnaugh map to minimize the following standard SOP expression:

$$\overline{A}\overline{B}\overline{C} + \overline{A}B\overline{C} + \overline{A}\overline{B}C + \overline{A}B\overline{C} + \overline{A}\overline{B}\overline{C}$$

Solution

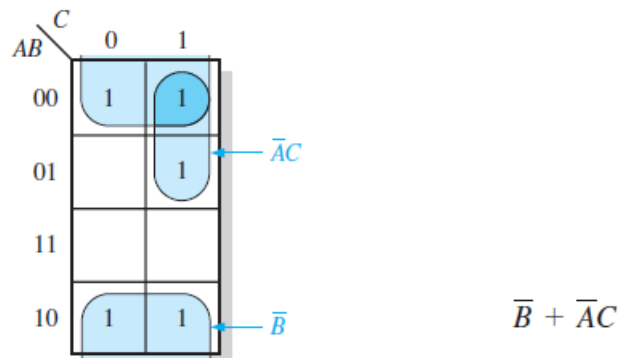



Example 5

Use a Karnaugh map to minimize the following SOP expression:

$$\overline{B}\overline{C}\overline{D} + \overline{A}\overline{B}\overline{C}\overline{D} + \overline{A}\overline{B}\overline{C}D + \overline{A}\overline{B}C\overline{D} + \overline{A}\overline{B}CD + \overline{A}B\overline{C}\overline{D} + \overline{A}B\overline{C}D + \overline{A}BC\overline{D} + \overline{A}BCD$$

Solution

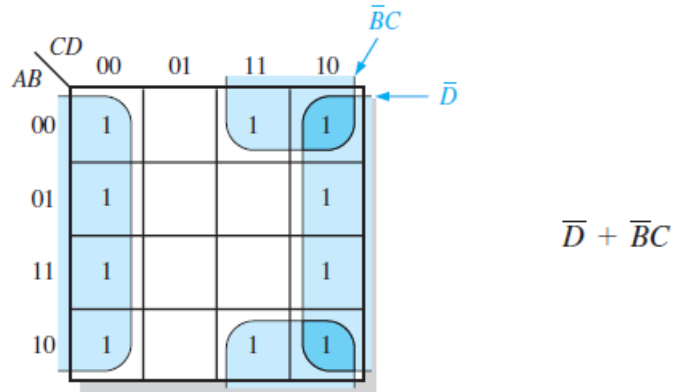

Mapping Directly from a Truth Table:

1- Truth table

Input		Output
A	B	Y
0	0	0
0	1	1
1	0	1
1	1	1

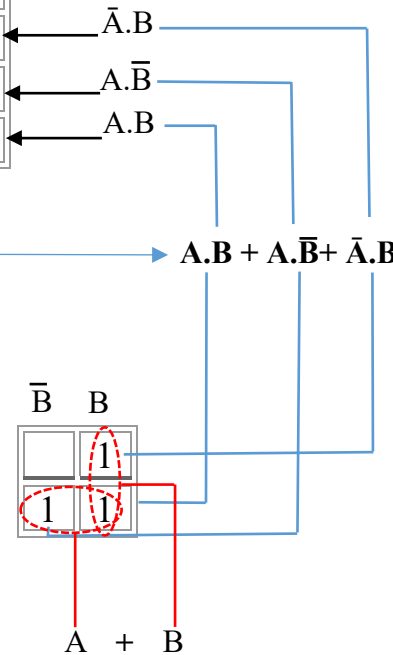

2- Minterm Boolean expression

$$A.B + A.\overline{B} + \overline{A}.B$$

3- Plotting 1s on map

4- Looping

5- The final result is $A+B = Y$



Example of the use of “don’t care” conditions to simplify an expression

Inputs				Output
A	B	C	D	Y
0	0	0	0	0
0	0	0	1	0
0	0	1	0	0
0	0	1	1	0
0	1	0	0	0
0	1	0	1	0
0	1	1	0	0
0	1	1	1	1
1	0	0	0	1
1	0	0	1	1
1	0	1	0	X
1	0	1	1	X
1	1	0	0	X
1	1	0	1	X
1	1	1	0	X
1	1	1	1	X

(a) Truth table

Don't cares

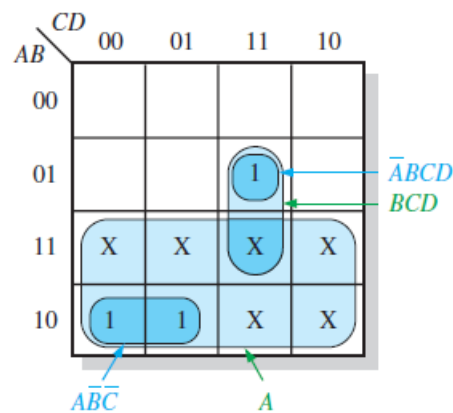

(b) Without “don’t cares” $Y = A\bar{B}\bar{C} + \bar{A}\bar{B}CD$
 With “don’t cares” $Y = A + BCD$



Karnaugh Map POS Minimization

Mapping a Standard POS Expression

The following steps and the illustration in the Figure below show the mapping process.

Step 1: Determine the binary value of each sum term in the standard POS expression.

This is the binary value that makes the term *equal to 0*.

Step 2: As each sum term is evaluated, *place a 0 on the Karnaugh map* in the corresponding cell.

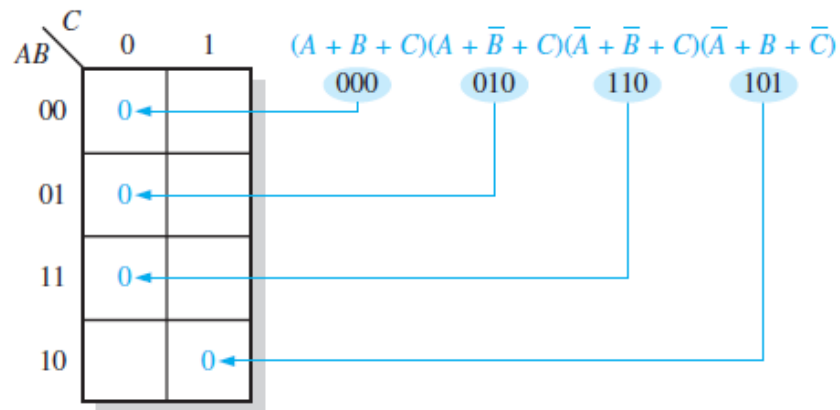

Example 1

Map the following standard POS expression on a Karnaugh map:

$$(\bar{A} + \bar{B} + C + D)(\bar{A} + B + \bar{C} + \bar{D})(A + B + \bar{C} + D)(\bar{A} + \bar{B} + \bar{C} + \bar{D})(A + B + \bar{C} + \bar{D})$$

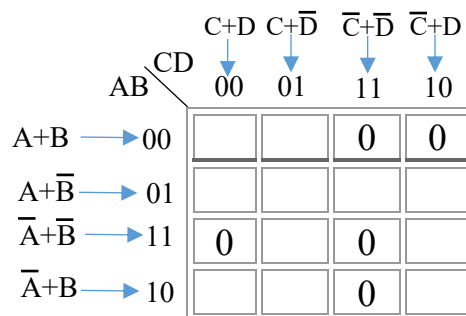



Karnaugh Map Simplification of POS Expressions

Example

Use a Karnaugh map to minimize the following standard POS expression

$$(A + B + C)(A + B + \bar{C})(A + \bar{B} + C)(A + \bar{B} + \bar{C})(\bar{A} + \bar{B} + C)$$

Solution

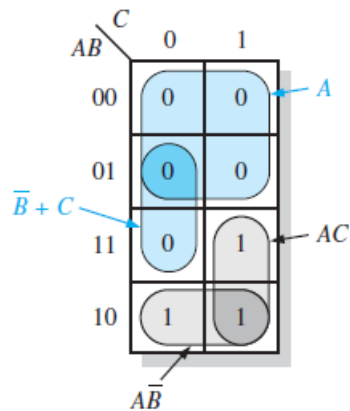

The result in POS is $A(\bar{B} + C)$

The result is SOP is $AC + \bar{A}\bar{B} = A(\bar{B} + C)$

Example

Use a Karnaugh map to minimize the following POS expression:

$$(B + C + D)(A + B + \bar{C} + D)(\bar{A} + B + C + \bar{D})(A + \bar{B} + C + D)(\bar{A} + \bar{B} + C + D)$$

Solution

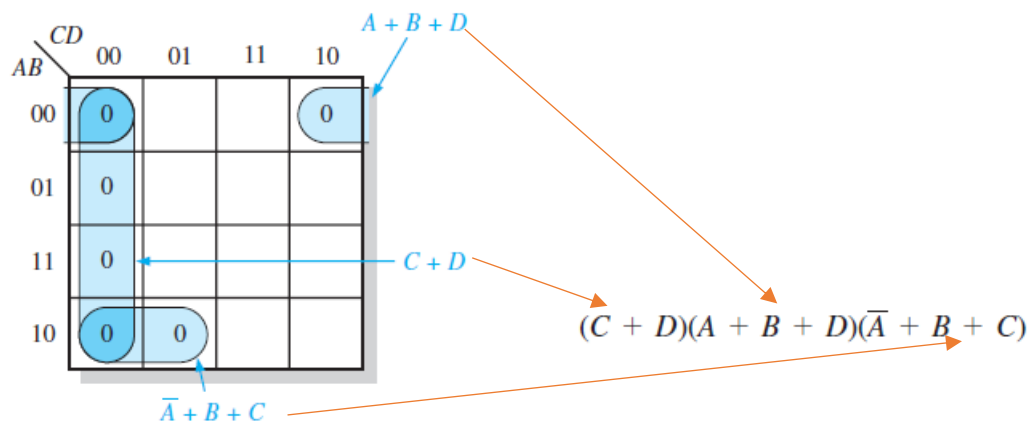

Converting Between POS and SOP Using the Karnaugh Map

Example

Using a Karnaugh map, convert the following standard POS expression into a minimum POS expression, a standard SOP expression, and a minimum SOP expression

$$(\bar{A} + \bar{B} + C + D)(A + \bar{B} + C + D)(A + B + C + \bar{D})(A + B + \bar{C} + \bar{D})(\bar{A} + B + C + \bar{D})(A + B + \bar{C} + D)$$

Solution

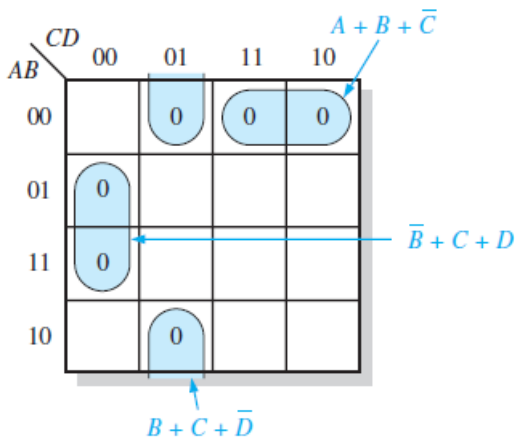

a) Minimum POS: $(A + B + C)(\bar{B} + \bar{C} + D)(B + C + \bar{D})$

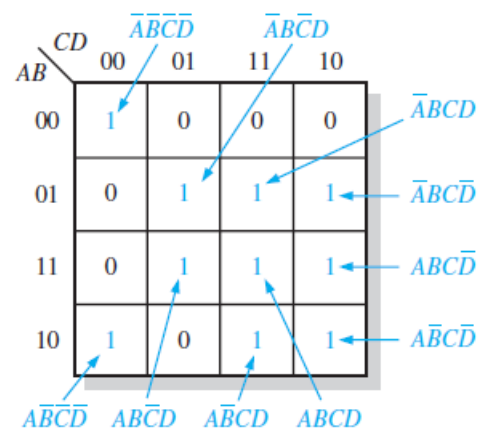

(b) Standard SOP:
 $\bar{A}\bar{B}\bar{C}\bar{D} + \bar{A}\bar{B}\bar{C}D + \bar{A}BC\bar{D} + \bar{A}BCD + A\bar{B}\bar{C}\bar{D} + A\bar{B}\bar{C}D + A\bar{B}C\bar{D} + A\bar{B}CD$

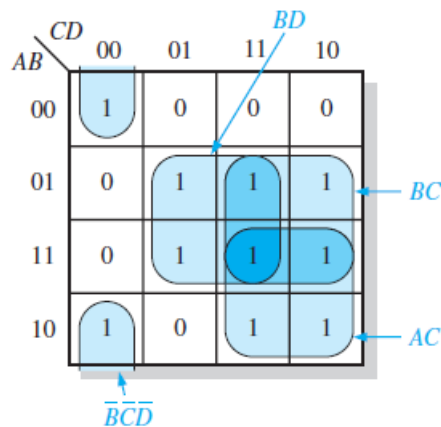

(c) Minimum SOP: $AC + BC + BD + \bar{B}\bar{C}\bar{D}$