



Al-Mustaqbal University

College of Engineering

Department of Biomedical Engineering

Stage: 4th

Microcontroller

2025-2026

Lecture ():

PC Interfacing

Fourth Level

Lecture

Analog to Digital Converters

By

Prof.Dr.Ibrahim A.Murdas

Analog to Digital Converters:-

Analog to Digital Converters (ADC) are an electronic integrated circuit (IC) which transforms a signal from analog (continuous) to digital (discrete) form. Analog signals are directly measurable quantities. Digital signals only have two states. For digital computer, we refer to binary states, 0 and 1.

Why ADC is needed:-

ADC is needed for many reasons but the most important are: Microprocessors can only perform complex processing on digitized signals. When signals are in digital form they are less susceptible to the deleterious effects of additive noise. Also ADC Provides a link between the analog world of transducers and the digital world of signal processing and data handling.

Application of ADC:-

ADCs are used virtually everywhere where an analog signal has to be processed, stored, or transported in digital form. Some examples of ADC usage are digital volt meters, cell phone, thermocouples, and digital oscilloscope. Microcontrollers commonly used 8, 10, 12, or 16 bit ADCs.

Classification of ADC according to accuracy and speed:-

ADC can be classified into two general groups based on the accuracy and speed:-

The first group includes successive-approximation, counter, and flash-type converters.

The second group includes integrator converters and voltage to frequency converters.

The tradeoff between two groups is based on accuracy VS speed. The successive-approximation and flash-type converters are faster but generally less accurate than the integrator and voltage to frequency type converters. Furthermore, the flash-type is expensive and difficult to design for high accuracy.

The most commonly used ADC: The successive-approximation and the integrator. The successive-approximation is used in applications such as data loggers, and instrumentation, where conversion speed is important. The integrator types are used in applications such as digital meter, and monitoring system where the conversion accuracy is critical.

ADC process:-

There are two steps process as shown in figure below:-

1. Sampling and Holding (S/H).
2. Quantizing and Encoding (Q/E).

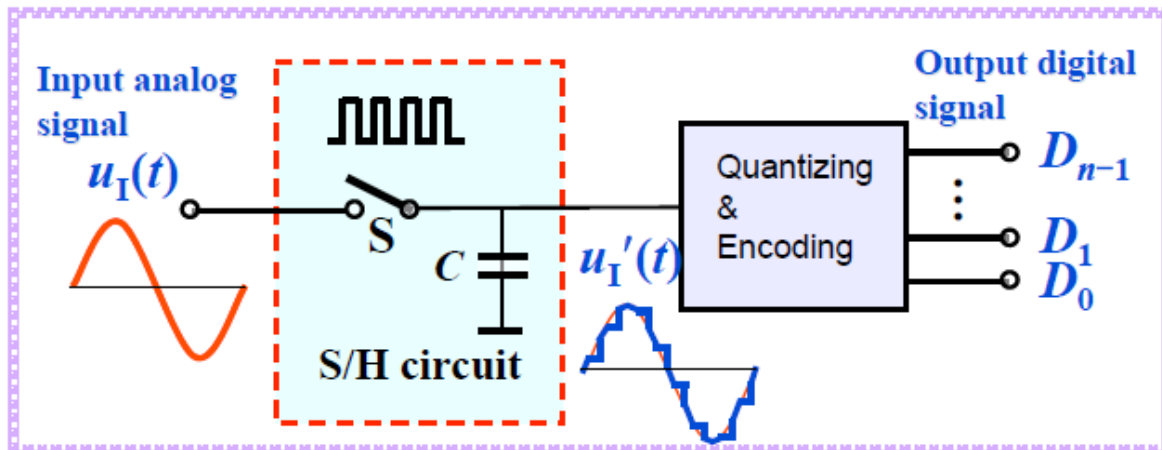

Sampling and Holding:-

It is a process of taking a sufficient number of discrete values at point on a waveform that will define the shape of waveform. The more samples you take, the more accurately you will define the waveform. It converts analog signal into series of impulses, each representing amplitude of the signal at given point as shown in figure below.

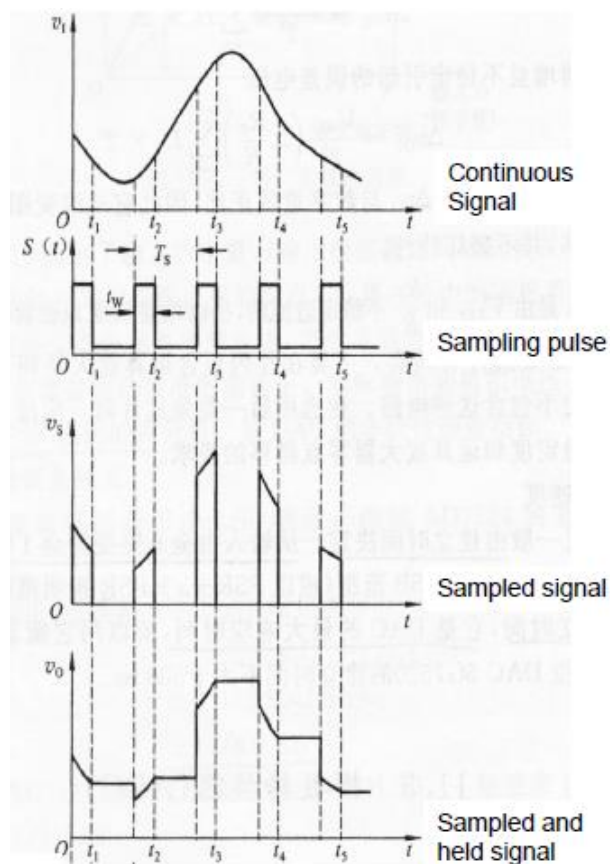

Quantizing and Encoding:-

Quantizing - is the process of converting the sampled continuous signals into discrete-valued data (set of finite states).

Encoding - assigning a digital word or number to each state and matching it to the input signal.

The number of possible states that the converter can output is:

$$N=2^n$$

Where n is the number of bits in the ADC.

Example: if you have 0-10V signals. What is the Discrete Voltage Ranges and Output Binary Equivalent by using 3 bit A/D converter?

Solution:-

$$N=2^n$$

For a 3 bit A/D converter, $N=2^3=8$.

Analog quantization size:

$$Q = (V_{\max} - V_{\min}) / N = (10V - 0V) / 8 = 1.25V$$

Step 1: Quantizing:

Output States	Discrete Voltage Ranges (V)
0	0.00-1.25
1	1.25-2.50
2	2.50-3.75
3	3.75-5.00
4	5.00-6.25
5	6.25-7.50
6	7.50-8.75
7	8.75-10.0

Step 2: Encoding:

Here we assign the digital value (binary number) to each state for the computer to read.

Output States	Output Binary Equivalent
0	000
1	001
2	010
3	011
4	100
5	101
6	110
7	111

Resolution:-

Resolution is the number of bits used for conversion (8 bits, 12 bits, ...)

- Resolution (number of discrete values the converter can produce) = Analog Quantization size (Q)
- $(Q) = V_{\text{range}} / 2^n$, where V_{range} is the range of analog voltages which can be represented
- In our previous example: $Q = 1.25V$, this is a high resolution. A lower resolution would be if we used a 2-bit converter, then the resolution would be $10/2^2 = 2.50V$.

Accuracy of A/D Conversion:-

There are two ways to best improve accuracy of A/D conversion:

- Increasing the resolution which improves the accuracy in measuring the amplitude of the analog signal.
- Increasing the sampling rate which increases the maximum frequency that can be measured.

■ Low Accuracy

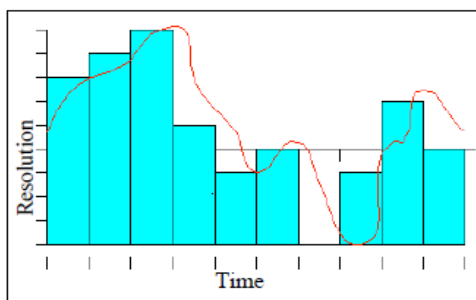

■ Improved

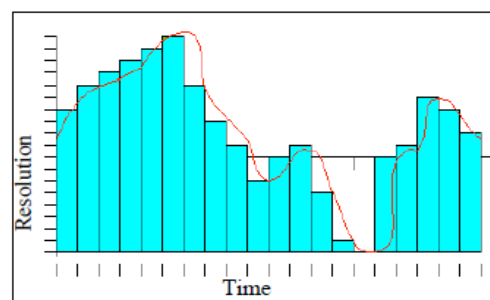

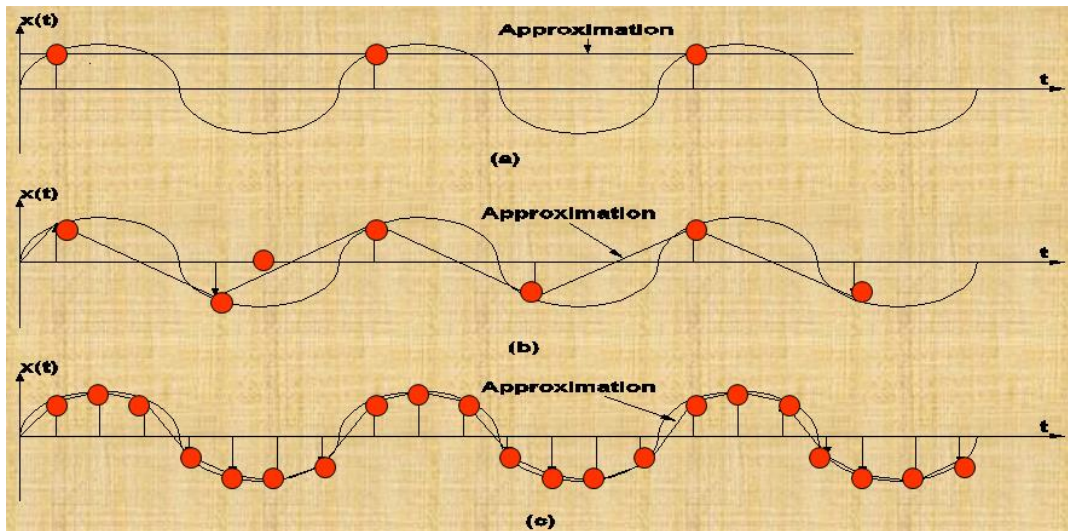

Overall Better Accuracy: Increasing both the sampling rate and the resolution you can obtain better accuracy in your AD signals.

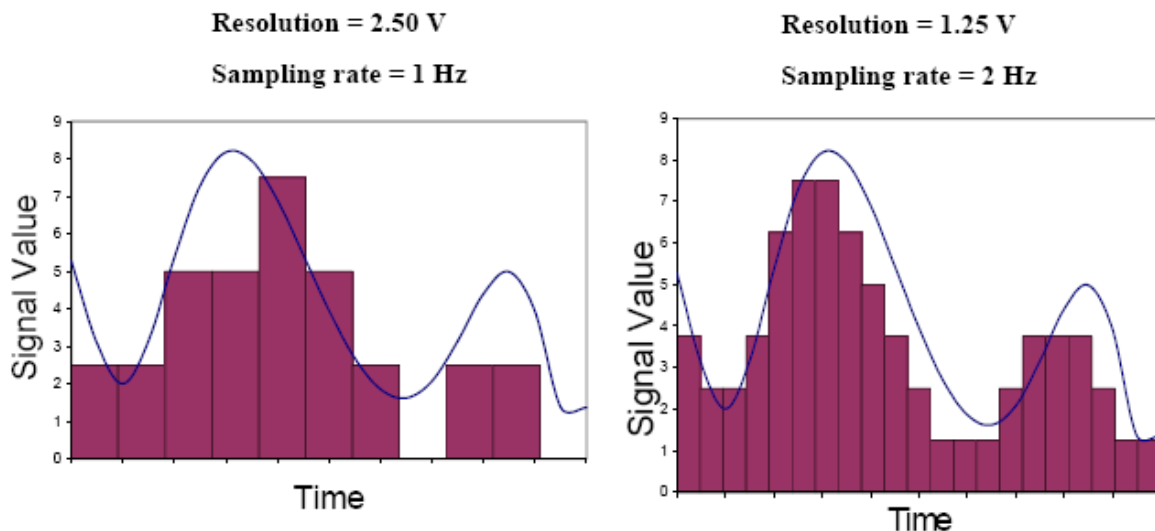

Types of A/D Converters

- Flash ADC
- Delta-Sigma ADC
- Dual Slope (integrating) ADC
- Successive Approximation ADC

1. Flash A/D Converter

Fundamental Components

Resistors use the resistors to form a ladder voltage divider, which divides the reference voltage into equal intervals.

Comparators Consists of a series of comparators, which comparing the input signal to a unique reference voltage.

Priority encoder the comparator outputs connect to the inputs of a priority encoder circuit, which produces a binary output.

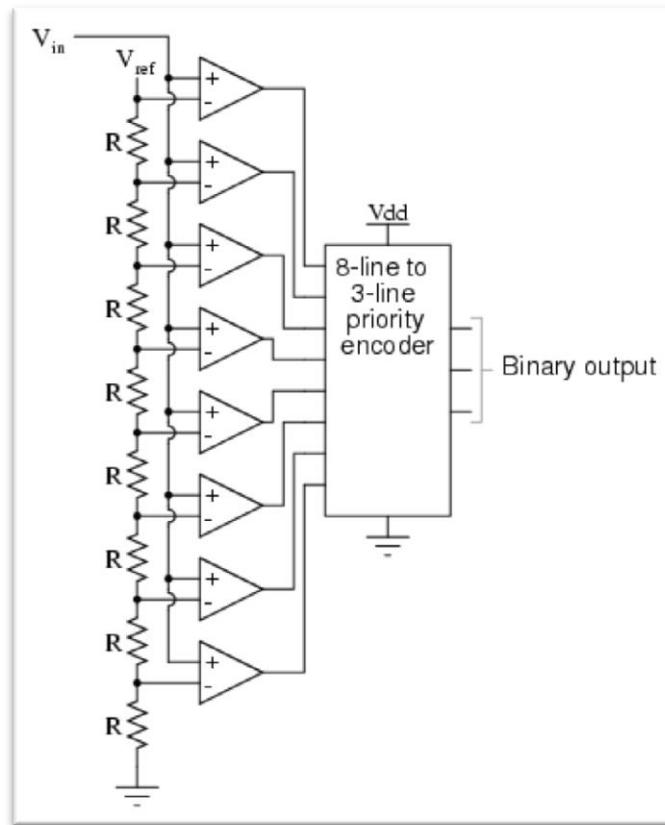

How does it work?

- Uses the comparators to determine in which the input voltage V_{in} is exceeded or not the V_{ref} .
- When the analog input voltage exceeds the reference voltage at each comparator, the comparator outputs will sequentially saturate to a high state.
- The priority encoder generates a binary number based on the highest-order active input, ignoring all other active inputs.

Advantages and Disadvantages

- Simplest in terms of operational theory, most efficient in terms of speed, very fast
- Lower resolution, Expensive, for each additional output bit, the number of comparators is increase.

2. Sigma Delta ADC

Main Components

- Resistors
- Integrator
- Capacitor
- Comparators
- Control Logic

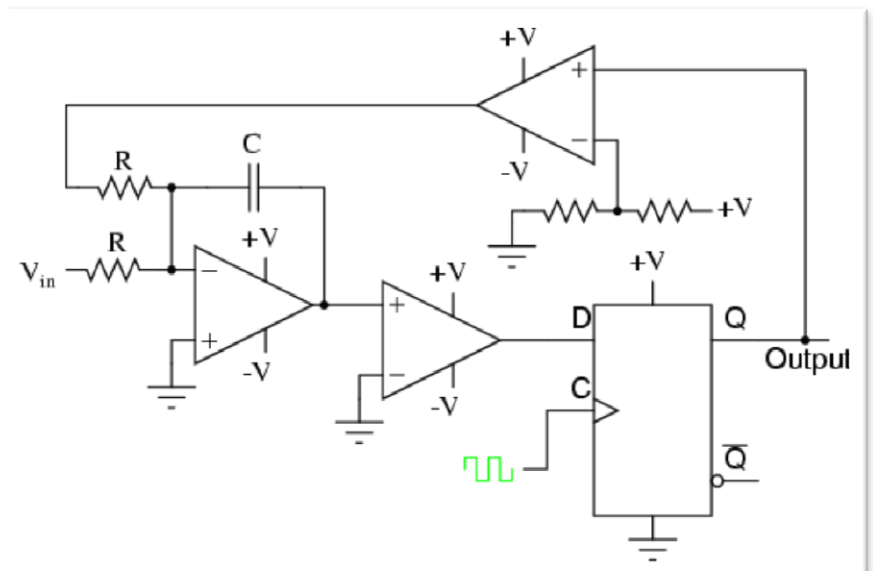

How does it work?

- Input is over sampled, and goes to integrator.
- The integration is then compared to ground.
- Iterates and produces a serial bit stream
- Output is a serial bit stream with # of 1's proportional to V_{in}

Advantages and Disadvantages

- High resolution, No need for precision components external.
- Slow due to oversampling.

3. Dual Slope Converter

Fundamental components

- Integrator
- Electronically Controlled Switches
- Counter
- Clock
- Control Logic
- Comparator

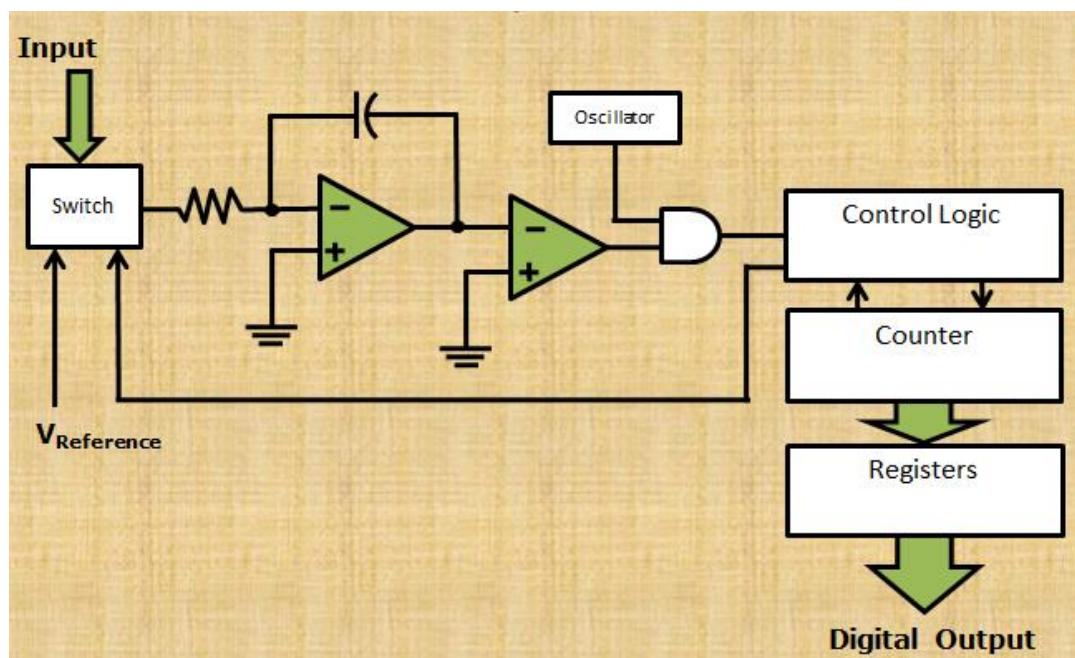

The Dual Slope ADC functions in this manner:

- When an analog value is applied, the capacitor begins to charge in a linear manner and the oscillator passes to the counter.
- The counter continues to count until it reaches a predetermined value. Once this value is reached the count stops and the counter is reset. The control logic switches the input to the first comparator to a reference voltage, providing a discharge path for the capacitor.
- As the capacitor discharges the counter counts.
- When the capacitor voltage reaches the reference voltage the count stops and the value is stored in the register.

Advantages and Disadvantages

- Conversion result is insensitive to errors in the component values, High Accuracy.
- Slow, Accuracy is dependent on the use of precision external components, Cost.

4. Successive Approximation ADC

- Much faster than the Dual Slope.
- A comparator and a DAC are used in the process.
- A Successive Approximation Register (SAR) is added to the circuit
- Instead of counting up in binary sequence, this register counts by trying all values of bits starting with the MSB and finishing at the LSB.
- The register monitors the comparators output to see if the binary count is greater or less than the analog signal input and adjusts the bits accordingly.

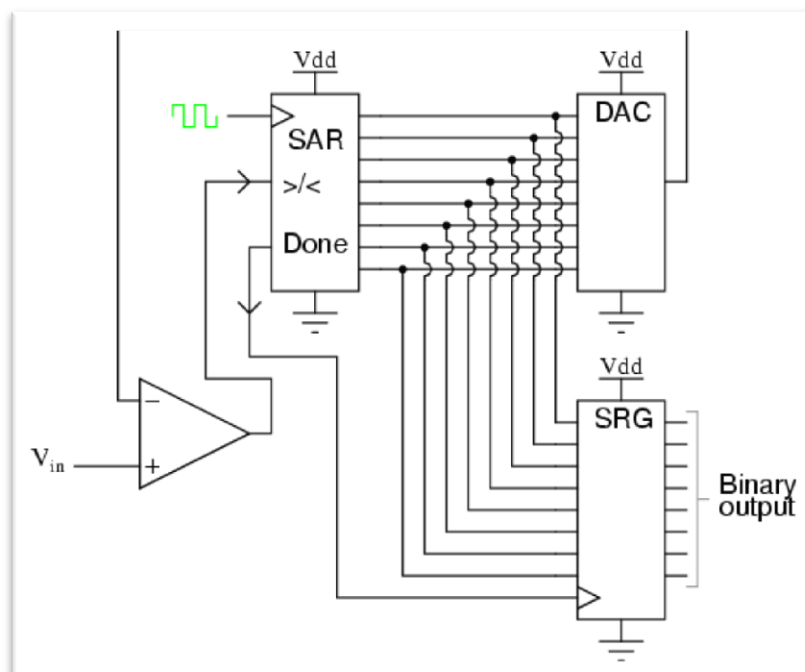

Advantages and Disadvantages

- Capable of high speed and reliable, medium accuracy compared to other ADC types, Good tradeoff between speed and cost.
- Higher resolution successive approximation ADC's will be slower.

ADC Specifications:

- Conversion time
- Resolution
- Accuracy
- Linearity
- Missing code