



Al-Mustaqbal University

College of Engineering

Department of Biomedical Engineering

Stage: 4th

Microcontroller

2025-2026

Lecture ( ):

**PC Interfacing**  
**Fourth Level**  
**Lecture**

**Digital to Analog Converters**

**By**

**Prof.Dr.Ibrahm AMurdas**

## Digital to Analog Converters

A digital to analog converter (DAC) converts a digital signal or values to an analog voltage or current output.

### Types of DACs

There are two types of DAC and usually used switches, resistors, and op-amps to implement conversion, two types are:

- Binary Weighted Resistor.
- R-2R Ladder.

### Binary Weighted Resistor:

- Weighted resistors are used to distinguish each bit from the most significant to the least significant.
- Switches are used to switch between  $V_{ref}$  and ground (bit high or low).
- $V_{out} = -IR_f$
- Voltages  $V_1$  to  $V_n$  are either  $V_{ref}$  if corresponding bit is high or ground if corresponding bit is low
- $V_1$  is most significant bit
- $V_n$  is least significant bit

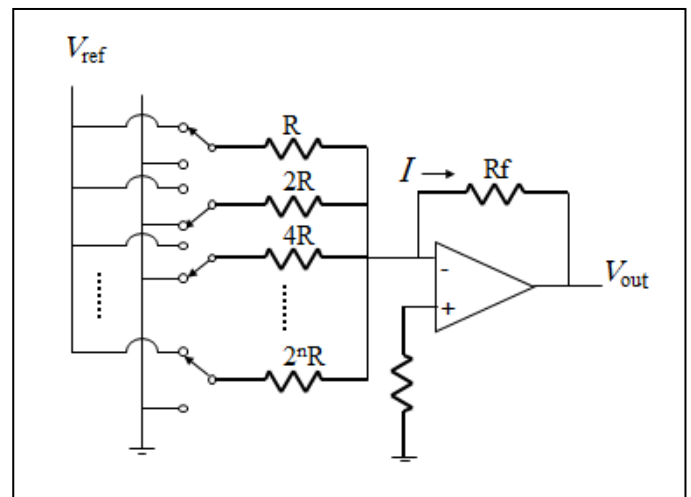

$$V_{out} = -IR_f = -R_f \left( \frac{V_1}{R} + \frac{V_2}{2R} + \frac{V_3}{4R} + \dots + \frac{V_n}{2^{n-1}R} \right)$$

If  $R_f = R/2$

$$V_{out} = -IR_f = - \left( \frac{V_1}{2} + \frac{V_2}{4} + \frac{V_3}{8} + \dots + \frac{V_n}{2^n} \right)$$

For example, a 4-bit converter yields

$$V_{out} = -V_{ref} \left( b_3 \frac{1}{2} + b_2 \frac{1}{4} + b_1 \frac{1}{8} + b_0 \frac{1}{16} \right)$$

Where  $b_3$  corresponds to Bit-3,  $b_2$  to Bit-2, etc.

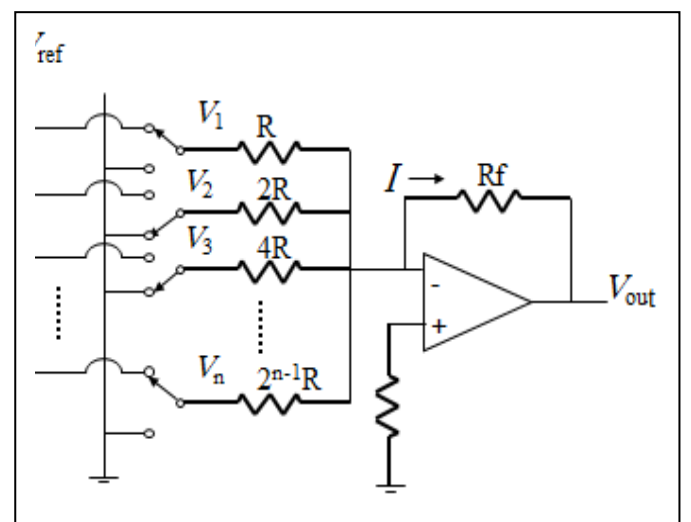

## Advantages and Disadvantages

- Simple Construction, Fast Conversion.
- Limited to ~ 8 bits, large number of resistors, susceptible to noise, expensive and greater error.

## R-2R Ladder:

- Each bit corresponds to a switch:
- If the bit is high, the corresponding switch is connected to the inverting input of the op-amp.
- If the bit is low, the corresponding switch is connected to ground.
- All bits pass through resistance of  $2R$

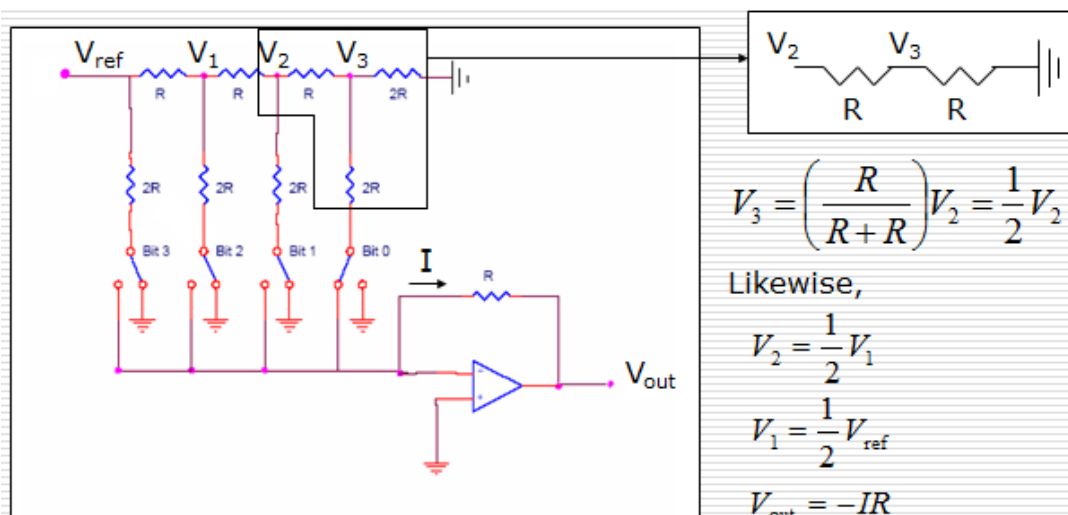
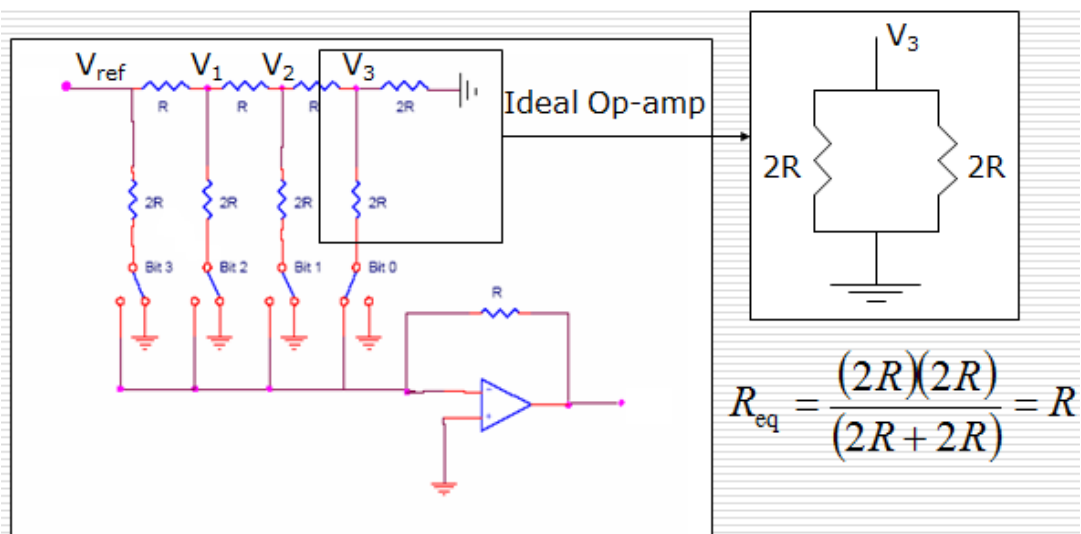
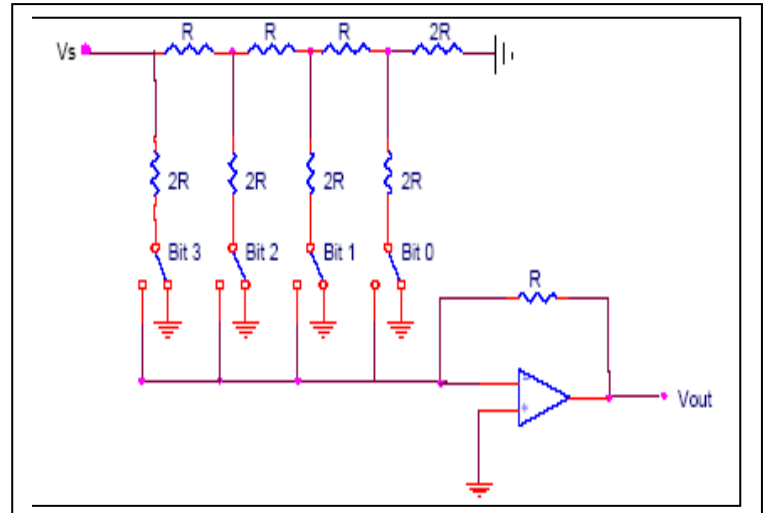

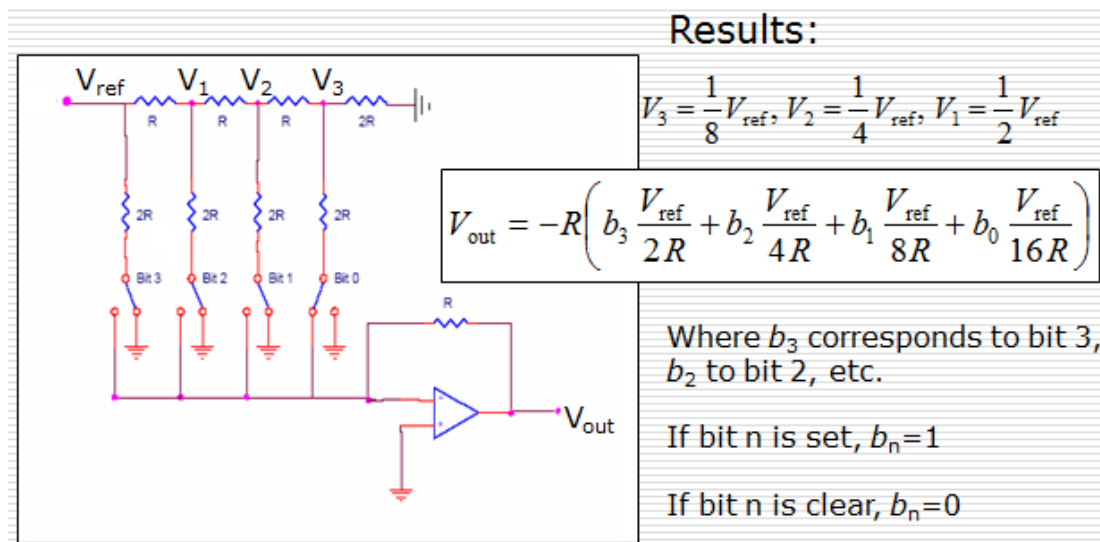

For a 4-Bit R-2R Ladder

$$V_{out} = -V_{ref} \left( b_3 \frac{1}{2} + b_2 \frac{1}{4} + b_1 \frac{1}{8} + b_0 \frac{1}{16} \right)$$

For general n-Bit R-2R Ladder or Binary Weighted Resistor DAC

$$V_{out} = -V_{ref} \sum_{i=1}^n b_{n-i} \frac{1}{2^i}$$

### Advantages and Disadvantages

- Only two resistors values (R and 2R), does not require high precision resistors.
- Lower conversion speed than binary weighted DAC.

### Specifications of DACs

- Resolution
- Speed
- Linearity
- Settling Time
- Reference Voltages
- Errors

**Resolution** is the amount of variance in output voltage for every change of the LSB in the digital input.

How closely can we approximate the desired output signal (Higher Res. = finer detail=smaller Voltage divisions)

Common DAC has an 8-16 bit resolution      Resolution =  $V_{LSB} = \frac{V_{ref}}{2^N}$

where  $N = \text{number of bits}$

**Speed** Rate of conversion of a single digital input to its analog equivalent.

Conversion rate depends on:

- clock speed of input signal
- settling time of converter

When the input changes rapidly, the DAC conversion speed must be high.

**Linearity** is the difference between the desired analog output and the actual output over the full range of expected values.

Ideally, a DAC should produce a linear relationship between a digital input and the analog output; this is not always the case.

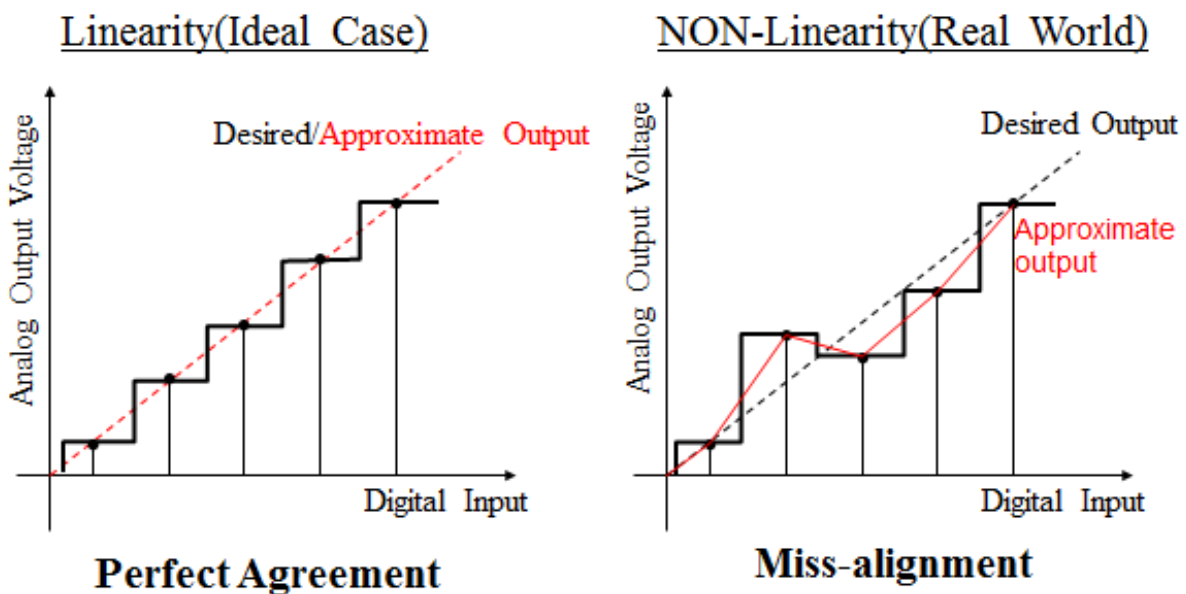

**Settling Time** The time required for the input signal voltage to settle to the expected output voltage (within  $\pm V_{LSB}$ ).

Any change in the input state will not be reflected in the output state immediately. There is a time lag, between the two events.

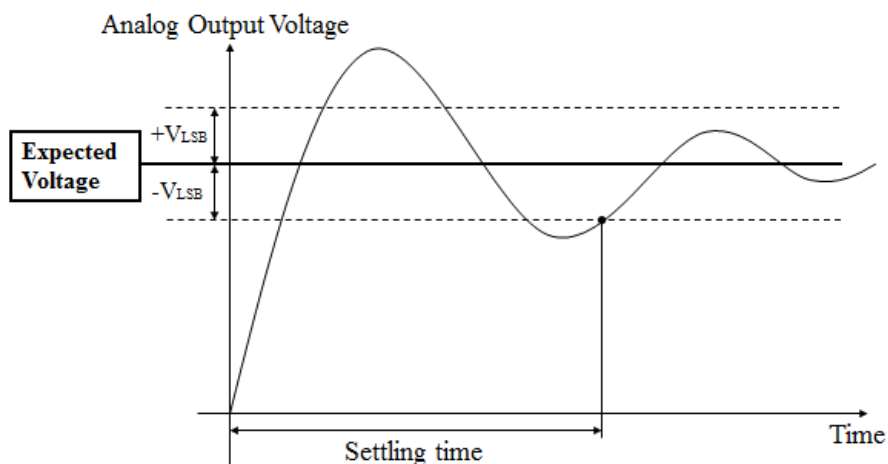

**Reference Voltages** used to determine how each digital input will be assigned to each voltage division.

Types:

- Non-multiplier DAC:  $V_{ref}$  is fixed (internal, fixed, and defined by manufacturer).
- Multiplier DAC:  $V_{ref}$  provided by external source (external, variable, user specified).

## Errors

### Types of Errors Associated with DACs

- Gain
- Offset
- Full Scale
- Resolution
- Non-Linearity
- Non-Monotonic

**Gain Error:** Difference in slope of the ideal curve and the actual DAC output.

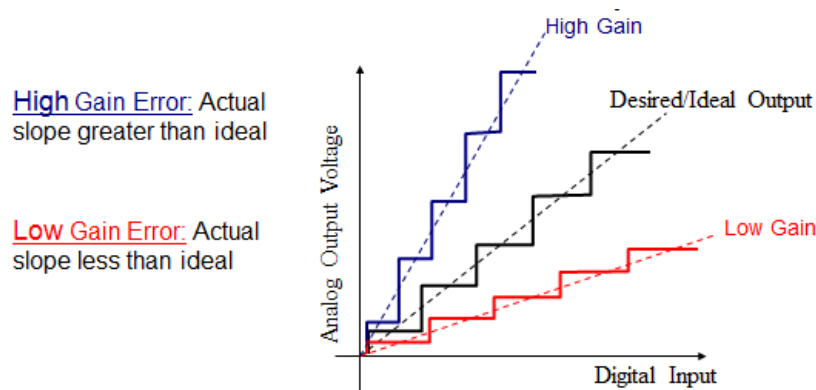

**Offset Error:** A constant voltage difference between the ideal DAC output and the actual.

- The voltage axis intercept of the DAC output curve is different than the ideal.

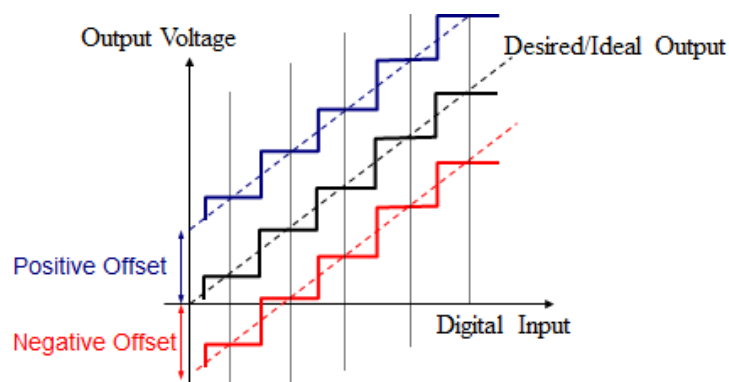

**Full Scale Error:** Occurs when the actual signal has both gain and offset errors.

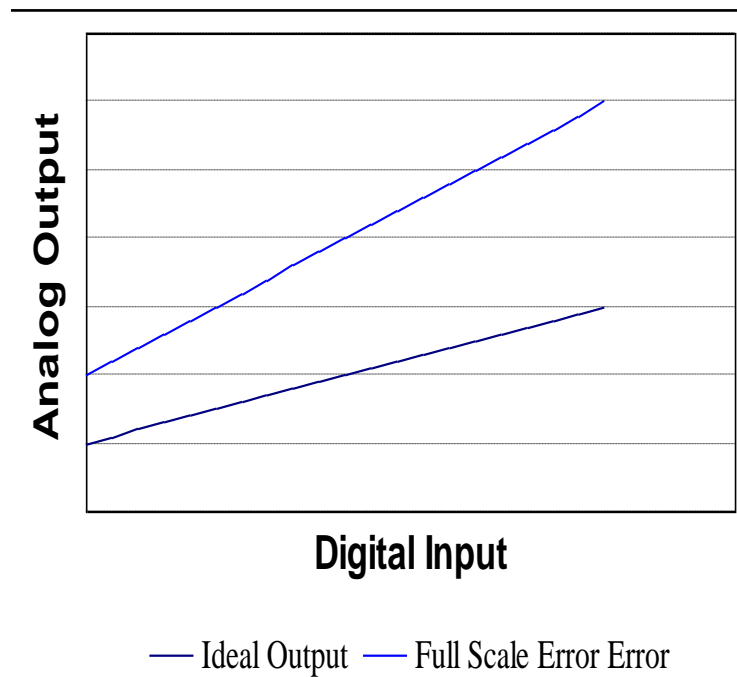

**Resolution Error:** Poor representation of ideal output due to poor resolution.

Size of voltage divisions affects the resolution

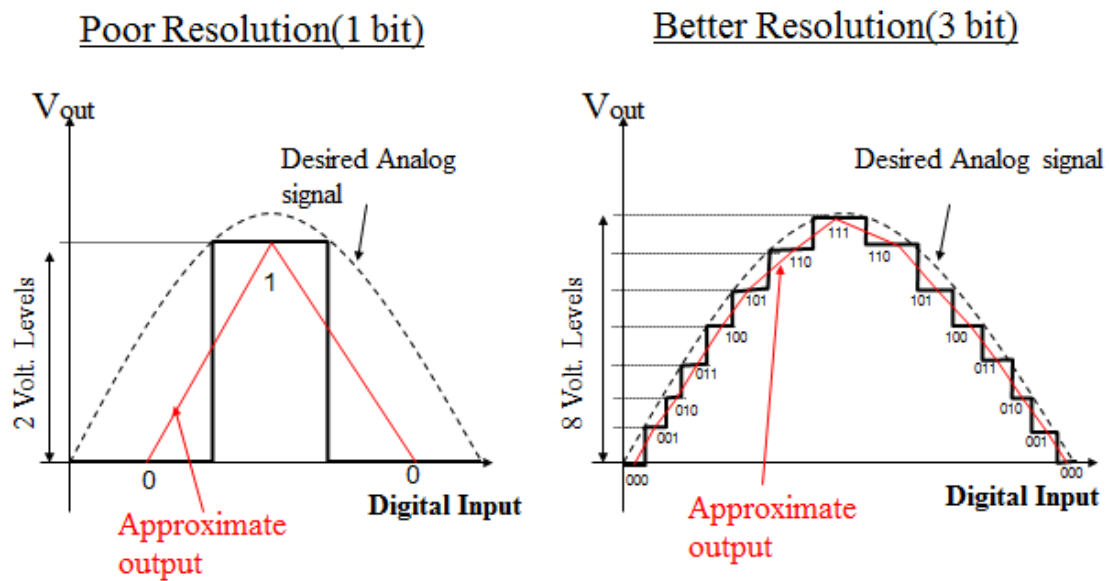

**Non-Linearity Error:** Occurs when analog output of signal is non-linear.

**Non-Monotonic:** A decrease in output voltage with an increase in the digital input.

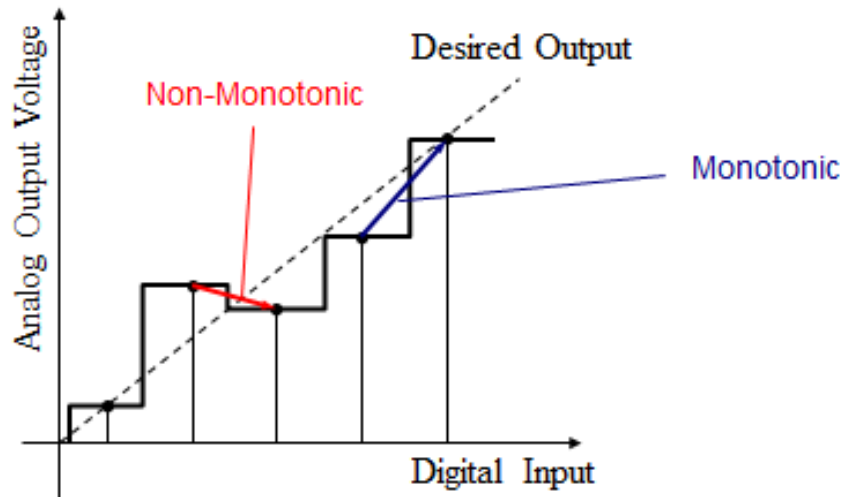

### Applications of DACs:

- Function Generators/Oscilloscopes.
- Digital Motor Control.
- Computer Printers.
- Sound Equipment (e.g. CD/MP3 Players, etc.).
- Electronic Cruise Control.
- Digital Thermostat.