

10.2 Principal Stresses and Maximum Shear Stress

For design purposes, the critical stresses at a point are often the maximum and minimum normal stresses and the maximum shear stress. The stress transformation equations can be used to develop additional relationships that indicate:

- (a) the orientations of planes where maximum and minimum normal stresses occur,
- (b) the magnitudes of maximum and minimum normal stresses,
- (c) the magnitudes of maximum shear stresses, and
- (d) the orientations of planes where maximum shear stresses occur.

The transformation equations for plane stress were developed for normal stress and shear stress, respectively, as follows:

$$\sigma_n = \sigma_x \cos^2 \theta + \sigma_y \sin^2 \theta + 2\tau_{xy} \sin \theta \cos \theta$$

$$\tau_{nt} = -(\sigma_x - \sigma_y) \sin \theta \cos \theta + \tau_{xy} (\cos^2 \theta - \sin^2 \theta)$$

These same equations can also be expressed in terms of double-angle trigonometric functions as:

$$\sigma_n = \frac{\sigma_x + \sigma_y}{2} + \frac{\sigma_x - \sigma_y}{2} \cos 2\theta + \tau_{xy} \sin 2\theta$$

$$\tau_{nt} = -\frac{\sigma_x - \sigma_y}{2} \sin 2\theta + \tau_{xy} \cos 2\theta$$

Principal Planes

For a given state of plane stress, the stress components σ_x , σ_y , and τ_{xy} are constants. The dependent variables σ_n and τ_{nt} are actually functions of only one independent variable, θ . Therefore, the value of θ for which the normal stress σ_n is a maximum or a minimum can be determined by differentiating Equation (10.3) with respect to θ and setting the derivative equal to zero:

$$\frac{d\sigma_n}{d\theta} = -\frac{\sigma_x - \sigma_y}{2} (2 \sin 2\theta) + 2\tau_{xy} \cos 2\theta = 0$$

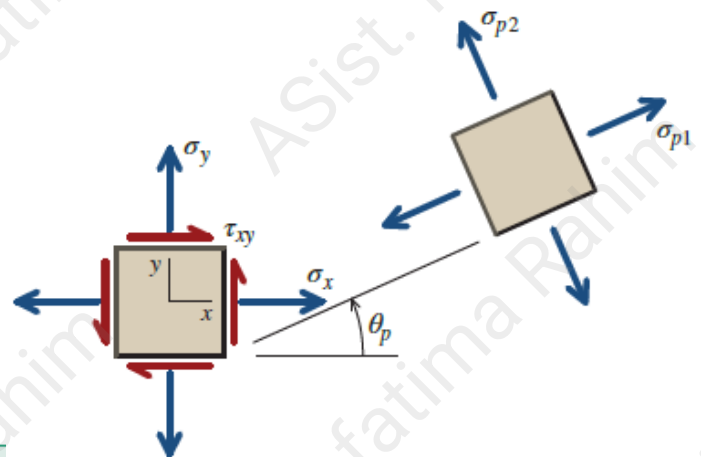

.....10.5

Planes free of shear stress are termed principal planes.

The two values of θ_p that obtained from Equation (10.6) are called the **principal angles**.

$$\tan 2\theta_p = \frac{2\tau_{xy}}{\sigma_x - \sigma_y}$$

.....10.6

The normal stresses acting on principal planes —the maximum and minimum normal stresses—are called **principal stresses**.

$$\sigma_{p1,p2} = \frac{\sigma_x + \sigma_y}{2} \pm \sqrt{\left(\frac{\sigma_x - \sigma_y}{2}\right)^2 + \tau_{xy}^2}$$

.....10.7

Shear Stresses on Principal Planes

If a plane is a principal plane, then the shear stress acting on the plane must be zero.

The converse of this statement is also true:

If the shear stress on a plane is zero, then that plane must be a principal plane.

Maximum In-Plane Shear Stress

To determine the planes where the maximum in-plane shear stress τ_{\max} occurs, Equation (10.4) is differentiated with respect to θ and set equal to zero, yielding

$$\frac{d\tau_{nt}}{d\theta} = -(\sigma_x - \sigma_y) \cos 2\theta - 2\tau_{xy} \sin 2\theta = 0 \quad \text{.....10.8}$$

The solution of this equation gives the orientation $\theta = \theta_s$ of a plane where the shear stress is either a maximum or a minimum:

$$\tan 2\theta_s = -\frac{\sigma_x - \sigma_y}{2\tau_{xy}} \quad \text{.....10.9}$$

The general equation can be derived to give the magnitude of τ_{\max} :

$$\tau_{\max} = \pm \sqrt{\left(\frac{\sigma_x - \sigma_y}{2}\right)^2 + \tau_{xy}^2} \quad \text{.....10.10}$$

Normal Stresses on Maximum In-Plane Shear Stress Surfaces

Unlike principal planes, which are free of shear stress, planes subjected to τ_{\max} usually have normal stresses. After substituting angle functions obtained from Equation (10.9) into Equation (10.3) and simplifying, we find that the normal stress acting on a plane of maximum in-plane shear stress is:

$$\sigma_{\text{avg}} = \frac{\sigma_x + \sigma_y}{2} \quad \text{.....10.11}$$

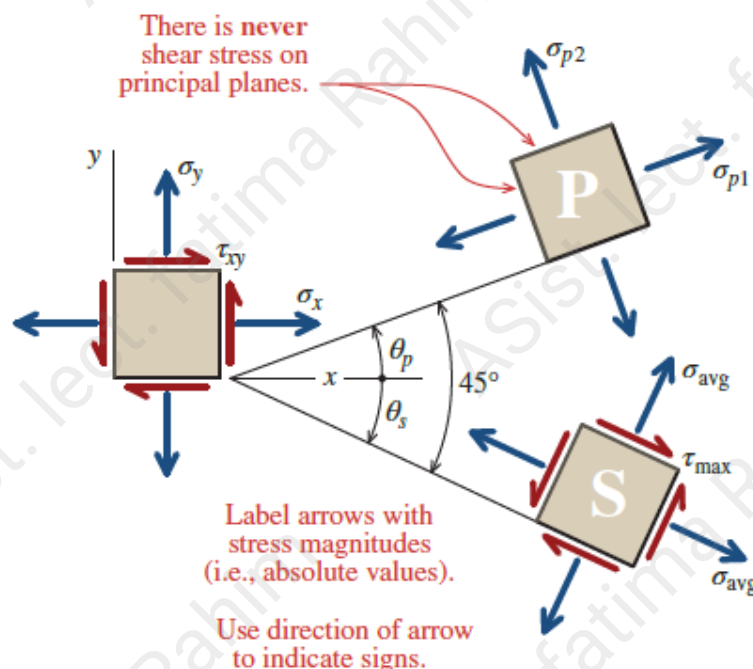

Example 10.3:

Consider a point in a structural member that is subjected to plane stress. Normal and shear stresses acting on horizontal and vertical planes at the point are shown.

(a) Determine the principal stresses and the maximum in-plane shear stress acting at the point.

(b) Show these stresses in an appropriate sketch.

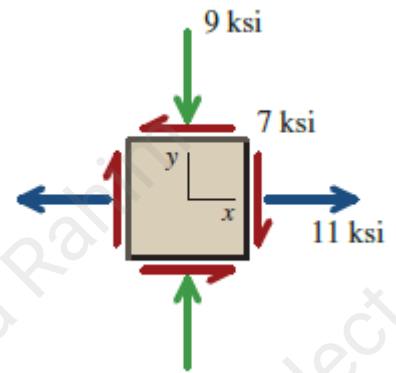

Solution:

(a) From the given stresses, the values to be used in the stress transformation equations are $\sigma_x = 11$ ksi, $\sigma_y = -9$ ksi, and $\tau_{xy} = -7$ ksi. The in-plane principal stress magnitudes can be calculated from Equation (10.12):

$$\begin{aligned}\sigma_{p1,p2} &= \frac{\sigma_x + \sigma_y}{2} \pm \sqrt{\left(\frac{\sigma_x - \sigma_y}{2}\right)^2 + \tau_{xy}^2} \\ &= \frac{(11 \text{ ksi}) + (-9 \text{ ksi})}{2} \pm \sqrt{\left(\frac{(11 \text{ ksi}) - (-9 \text{ ksi})}{2}\right)^2 + (-7 \text{ ksi})^2} \\ &= 13.21 \text{ ksi}, -11.21 \text{ ksi}\end{aligned}$$

Therefore, we have the following:

$$\sigma_{p1} = 13.21 \text{ ksi} = 13.21 \text{ ksi (T)}$$

$$\sigma_{p2} = -11.21 \text{ ksi} = 11.21 \text{ ksi (C)}$$

The maximum in-plane shear stress can be computed from Equation (10.10):

$$\begin{aligned}\tau_{\max} &= \pm \sqrt{\left(\frac{\sigma_x - \sigma_y}{2}\right)^2 + \tau_{xy}^2} = \pm \sqrt{\left(\frac{(11 \text{ ksi}) - (-9 \text{ ksi})}{2}\right)^2 + (-7 \text{ ksi})^2} \\ &= \pm 12.21 \text{ ksi}\end{aligned}$$

On the planes of maximum in-plane shear stress, the normal stress is simply the average normal stress, as given by Equation (10.17):

$$\sigma_{\text{avg}} = \frac{\sigma_x + \sigma_y}{2} = \frac{11 \text{ ksi} + (-9 \text{ ksi})}{2} = 1 \text{ ksi} = 1 \text{ ksi (T)}$$

(b) The principal stresses and the maximum in-plane shear stress must be shown in an appropriate sketch. The angle θ_p indicates the orientation of one principal plane relative to the reference x face. From Equation (10.6),

$$\begin{aligned}\tan 2\theta_p &= \frac{2\tau_{xy}}{\sigma_x - \sigma_y} = \frac{2(-7 \text{ ksi})}{11 \text{ ksi} - (-9 \text{ ksi})} = \frac{-14}{20} \\ \therefore \theta_p &= -17.5^\circ\end{aligned}$$

Since θ_p is negative, the angle is turned clockwise. In other words, the *normal* of one principal plane is rotated 17.5° below the reference x axis. One of the in-plane principal stresses—either σ_{p1} or σ_{p2} —acts on this principal plane. To determine which principal stress acts at $\theta_p = -17.5^\circ$, use the following two-part rule:

- If the term $\sigma_x - \sigma_y$ is positive, then θ_p indicates the orientation of σ_{p1} .
- If the term $\sigma_x - \sigma_y$ is negative, then θ_p indicates the orientation of σ_{p2} .

Since $\sigma_x - \sigma_y$ is positive, θ_p indicates the orientation of $\sigma_{p1} = 13.21$ ksi. The other principal stress, $\sigma_{p2} = -11.21$ ksi, acts on a perpendicular plane. The in-plane principal stresses are shown on the element labeled “P” in the figure. Note that there are never shear stresses acting on the principal planes.

The planes of maximum in-plane shear stress are always located 45° away from the principal planes; therefore, $\theta_s = 27.5^\circ$. Although Equation (10.16) gives the magnitude of the maximum in-plane shear stress, it does not indicate the direction in which the shear stress acts on the plane defined by θ_s . To determine the direction of the shear stress, solve Equation (10.4) for τ_{nt} , using the values $\sigma_x = 11$ ksi, $\sigma_y = -9$ ksi, $\tau_{xy} = -7$ ksi, and $\theta = \theta_s = 27.5^\circ$:

Since τ_{nt} is negative, the shear stress acts in a negative t direction on a positive n face. Once the shear stress direction has been determined for one face, the shear stress direction is known for all four faces of the stress element. The maximum in-plane shear stress and the average normal stress are shown on the stress element labeled “S.” Note that, unlike the principal stress element, normal stresses will usually be acting on the planes of maximum in-plane shear stress.

The principal stresses and the maximum in-plane shear stress can also be reported on a single wedge-shaped element, as shown in the accompanying sketch. This format can be somewhat easier to use than the two-element sketch format, particularly with regard to the direction of the maximum in-plane shear stress. The maximum in-plane shear stress and the associated average normal stress are shown on the sloped face of the wedge, which is rotated 45° from the principal planes. *The shear stress arrow on this face always starts on the σ_{p1} side of the wedge and points toward the σ_{p2} side of the wedge.* Once again, there is never a shear stress on the principal planes (i.e., the σ_{p1} and σ_{p2} sides of the wedge).

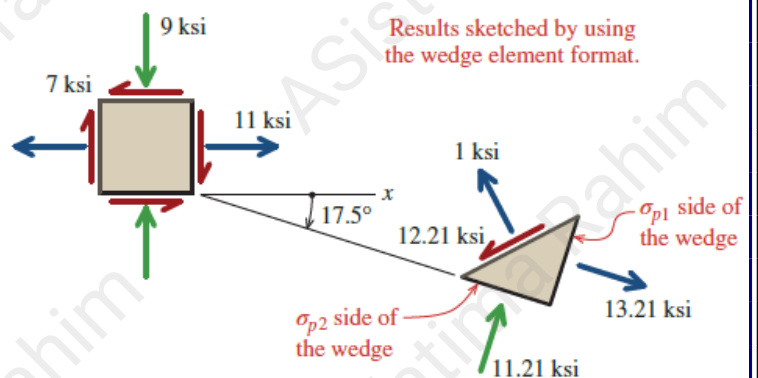
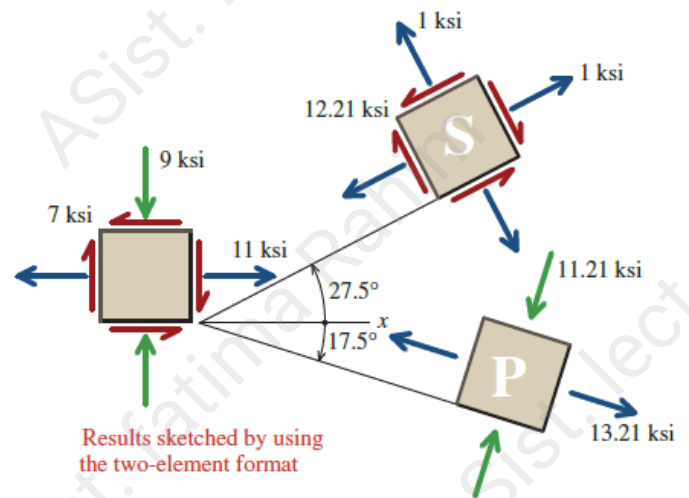

Example 10.4:

For the structural member, Determine:

- the principal stresses and the maximum in-plane shear stress acting at the point.
- Show these stresses in an appropriate sketch.

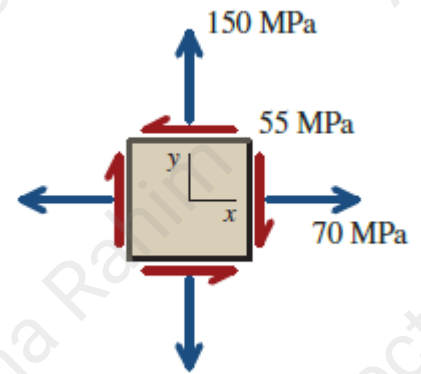
**Solution:**

$$\begin{aligned}\sigma_{p1,p2} &= \frac{\sigma_x + \sigma_y}{2} \pm \sqrt{\left(\frac{\sigma_x - \sigma_y}{2}\right)^2 + \tau_{xy}^2} \\ &= \frac{70 \text{ MPa} + 150 \text{ MPa}}{2} \pm \sqrt{\left(\frac{70 \text{ MPa} - 150 \text{ MPa}}{2}\right)^2 + (-55 \text{ MPa})^2} \\ &= 178.0 \text{ MPa}, 42.0 \text{ MPa}\end{aligned}$$

The *maximum in-plane shear stress* can be computed from Equation (12.15):

$$\begin{aligned}\tau_{\max} &= \pm \sqrt{\left(\frac{\sigma_x - \sigma_y}{2}\right)^2 + \tau_{xy}^2} = \pm \sqrt{\left(\frac{70 \text{ MPa} - 150 \text{ MPa}}{2}\right)^2 + (-55 \text{ MPa})^2} \\ &= \pm 68.0 \text{ MPa}\end{aligned}$$

On the planes of maximum in-plane shear stress, the normal stress is simply the *average normal stress*, as given by Equation (12.17):

$$\sigma_{\text{avg}} = \frac{\sigma_x + \sigma_y}{2} = \frac{70 \text{ MPa} + 150 \text{ MPa}}{2} = 110 \text{ MPa} = 110 \text{ MPa (T)}$$

The principal stresses and the maximum in-plane shear stress must be shown in an appropriate sketch. The angle θ_p indicates the orientation of one principal plane relative to the reference x face. From Equation (10.6),

$$\begin{aligned}\tan 2\theta_p &= \frac{2\tau_{xy}}{\sigma_x - \sigma_y} = \frac{2(-55 \text{ MPa})}{70 \text{ MPa} - 150 \text{ MPa}} = \frac{-110}{-80} \\ \therefore \theta_p &= 27.0^\circ\end{aligned}$$

The angle θ_p is positive; consequently, the angle is turned counterclockwise from the x axis. Since $\sigma_x - \sigma_y$ is negative, θ_p indicates the orientation of $\sigma_{p2} = 42.0 \text{ MPa}$. The other principal stress, $\sigma_{p1} = 178.0 \text{ MPa}$, acts on a perpendicular plane. The in-plane principal stresses are shown in the accompanying figure. The maximum in-plane shear stress and the associated average normal stress are shown on the sloped face of the wedge, which is rotated 45° from the principal planes. Note that the arrow for τ_{\max} starts on the σ_{p1} side of the wedge and points toward the σ_{p2} side.

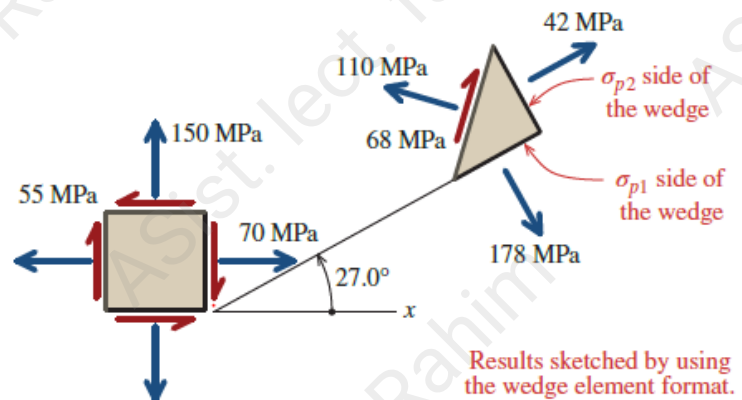

Results sketched by using the wedge element format.