



**Al-Mustaqbal University**  
**College of Science**  
**Department of Forensic Evidence**  
**First Stage**



جامعة المستقبل  
AL MUSTAQBAL UNIVERSITY

**College of Science**  
**Department of Forensic Evidence**

## **LECTURE (3)**

**Electricity and Magnetism**  
**Conduction and Resistance**

**First stage**

**Msc. Hussein Ali**

**2025-2026**



## Conduction and Resistance

- A. Charge flows very easily through some kinds of materials, like copper. Material that easily conducts, or carries, electrical current is called a **conductor**.
- B. Other materials, like glass or plastic, do not allow charge to flow. These materials are called **insulators** because they insulate or block the flow of current.
- C. A third category of materials are not as easy-flowing for current as conductors, but they are not quite insulators either. These materials are named **semiconductors**. Semiconductors are very important for computer chips.

## Conduction

- A. The property of a material to allow charge to flow is called its electrical conductivity. All materials have some degree of conductivity - those with high conductivity are conductors. Materials with low conductivity are insulators.

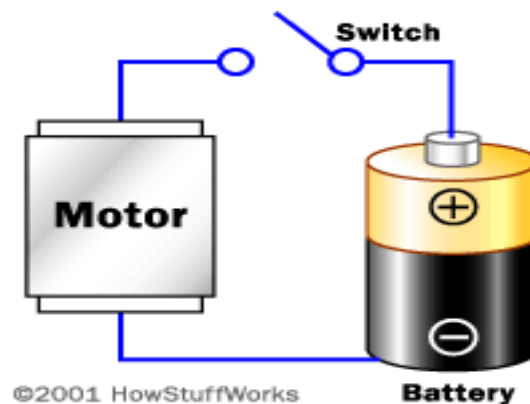

- B. Examples of conductors include silver, copper, gold, aluminum, and tungsten.
- C. Examples of insulators include rubber, paper, plastics, and glass.

## Resistance

- A. The resistance of an object measures how difficult it is for charges to flow through something. High resistance means it is difficult for current to flow. Low resistance means it is easy for current to flow.



- B. Devices that use electrical energy have resistance. For example, light bulbs have resistance. If you string more light bulbs together, the resistance adds up and the current goes down.
- C. Electrical resistance is measured in units called ohms. The unit is abbreviated with the Greek letter omega ( $\Omega$ ).
- D. Voltage and resistance together determine how much current flows in a circuit. If voltage goes up, current goes up. If resistance goes up, current goes down.

Electric Current – net movement or flow of charges in a single direction through a wire or conductor.

Potential Difference (Voltage)– force that causes electric charges to flow; charges flow from high voltage low voltage

Resistance – tendency for a material to oppose the flow of electrons, changing electrical energy into thermal and light energy.

**Circuit – a closed path that electric current follows.**



Battery, wires, and voltage difference allows current to flow.

**BATTERIES**

**Dry Cell**

Chemical reactions occur in a moist paste causing transfer of electrons



**Wet Cell**



**Al-Mustaqbal University**  
**College of Science**  
**Department of Forensic Evidence**  
**First Stage**



Contains two connected plates made of different metals in conducting solution.

Ex. Car Battery



Making wires thinner, longer or hotter increases resistance. All materials have some electrical resistance measured in ohms. ( $\Omega$ )

Ohms Law – current in a circuit equals Potential difference (Voltage) divided by resistance.

$$\text{Current} = \frac{\text{potential Diff.}}{\text{resistance}}$$

## Summary

A. Voltage is a measure of energy of a system. Energy flows anytime there is a voltage difference. Current flows from high voltage to low voltage.

B. Current is a measure of how many charges flow through a circuit per second. Current is measured in Amperes, or amps.



## Review

1. We have covered three important electrical qualities so far – voltage, current, and resistance.
2. Remember that voltage is a measure of the energy level of a system. Any time there is a voltage difference a current flows. Voltage is measured in volts.
3. Current is a measure of how many charges flow through a circuit per second. The unit for current is amps.
4. Resistance is a measure of how difficult it is for current to flow. The unit for resistance is the ohm.

## How it all fits together?

Voltage, current, and resistance are all related. If you increase the voltage of a circuit, the current goes up. If you increase the resistance of a circuit, the current goes down.



## **How it all fits together?**

The relationship between voltage, current, and resistance can be summarized in a mathematical relationship called Ohm's law:

$$I = \frac{V}{R}$$

## Ohm's Law

You can manipulate ohm's law to find either current, voltage, or resistance of a circuit if you know any two of the three components in a circuit.

To find voltage of a circuit, use

$$V = I \times R$$

C. To find resistance of a circuit, use

$$R = V/I$$